

PAKISTAN JOURNAL OF DISTANCE EDUCATION

Volume — X

1993

Issue — I & II



Allama Iqbal Open University
Islamabad — Pakistan

PAKISTAN JOURNAL OF DISTANCE EDUCATION

1993

Volume-X

Issue-I & II



Research and Evaluation Centre
Allama Iqbal Open University:
Islamabad — Pakistan

COPYRIGHT

1993

ALLAMA IQBAL OPEN UNIVERSITY

SECTOR H-8, ISLAMABAD

PAKISTAN

SUBSCRIPTION

YEARLY : RS.35.00

SINGLE COPY : RS.20.00

FOREIGN

INDIVIDUALS : US \$ 12.00

LIBRARIES AND : US \$ 15.00

INSTITUTIONS

PRINTED AND PUBLISHED BY
ALLAMA IQBAL OPEN UNIVERSITY,
ISLAMABAD, PAKISTAN.

COMPOSED BY : SAEED AKHTER

TO THE READER

Pakistan Journal of Distance Education is dedicated to the distance-learning system rapidly growing in Asia and the world over. The Journal welcomes studies, research and reviewer papers dealing with past, present and future perspectives of distance education, with a view to awakening further interest in the newly growing discipline and opening new vistas of research.

Authors are advised to send two copies of manuscripts, retaining one with them for reference. The submission of a manuscript will be taken to imply that the material has not been previously published. Work included in the manuscript but done by the author in other places should be clearly acknowledged.

Views expressed in this Journal are those of authors and do not necessarily reflect the views of the Pakistan Journal of Distance Education.

Articles may be sent to:

Coordinator,
Pakistan Journal of Distance Education,
Research and Evaluation Centre,
Allama Iqbal Open University,
Sector H-8,
Islamabad _____ Pakistan.

The Journal is published twice a year in Spring and Autumn by the Research and Evaluation Centre of Allama Iqbal Open University, Islamabad, Pakistan.

EDITORIAL BOARD

Dr. Muhammad Tariq Siddiqi
Vice-Chancellor
Patron-in-Chief

Prof. Javed Iqbal Syed
Editor-in-Chief

Dr. Mahmudur Rahman
Editor

Ms. Masooda Chaudhry
Associate Editor

Member of the Editorial Board

Dr. S. Attaullah Shirazi
Dr. Mrs. Shamim Abbas
Dr. Muhammad Rashid
Dr. Ahmed Noor Khan (Ex-Editor)

Adviser

Mr. Alec Fleming (UKOU)
British Project Team

Coordinator

Altaf Hussain Memon

PAKISTAN JOURNAL OF DISTANCE EDUCATION

Volume-X

1993

Issue-I & II

C O N T E N T S

Pages

Editorial Mahmudur Rahman	Distance Education: Need of the Day	vii
Konard Michalski	Towards More effective use of Computer Resources in Distance Education Institutions	1
S. Attaullah Shirazi and Naseer Ahmed	The Level and Range of Science and Technology Courses at Allama Iqbal Open University-Islamabad	16
John R. Minnis	Instructional Design Principles Derived from cognitive psychology: Implications for Distance Education	29
M.K. Bacchus	The contributions of Asian Open Universities in Moderating the Rising Cost of Higher Education	48
Janet Jenkins	Current Developments in Distance Education: An Open Lecture presented at Allama Iqbal Open University	59

RESEARCH NOTES

Eric A. Mensah	A Multi-Media approach to effective teaching: An Evaluation Report on the GCE (OL) Integrated Course at the Accra Workers College	70
----------------	---	----

WINDOW ON DISTANCE LEARNING INSTITUTIONS

Taiseer Zaid Kailani	A Case History/Research Note on Distance Education system of Al-Quds Open University: Amman	102
----------------------	---	-----

SPECIAL FEATURES

Mahmudur Rahman	Book Review	125
Masooda Chaudhry	Book Review	127
Iqbal Hussain	News and Views	129
Abdus Sattar Khan	Data Bank	145

PAKISTAN JOURNAL OF DISTANCE EDUCATION

Volume — X

1993

Issue — I & II



Allama Iqbal Open University
Islamabad — Pakistan

EDITORIAL

Distance Education: Need of the Day

Aristotle, the distinguished scholar and prominent philosopher of the world, had once observed that "it is natural for human being to desire to know". This very inhabitant longing has ever since paved the way for knowing about unknown, hidden and invisible elements of the universe. If there were no such inclinations, man would still have been wondering in the wilderness without having any aim and object, goal and gangway, purpose and proficiency, prog and progress. It is evidently the desire to know which has made the man master of universe and enabled him for smooth sailing of his life-boat through horrible storms of unfavourable time.

Thus, it is evident that this "natural desire to know" is the main source of splendid progress and prosperity of the human being. It has not to be nullified and negated in this supersonic age. We all have to endeavour enormously to enlarge the horizon of knowledge through education. Now the question arises whether we are able to achieve this glamouring goal merely by adopting formal way of education. Ironically, the answer is in negative. Today, the world population has reached to its peak. Poverty has gripped the world to such an extent that every citizen has to start work at very young age. Even the parents force their tiny tots to involve in labour for earning livelihood during their teenage. Under such circumstances and catasrophe, the major population is deprived of availing chances to be enrolled in school or college. They are amicably forced to work with hammer and hackle rather to take pen, pencil and paper to enlighten themselves with the rays of knowledge through attending education institutions. This is the dilemma of the day and nobody can close his eyes to this fatal fact of life.

The only solution to this menace and misery lies in distance education. It is a generic term that

includes the range of teaching and learning strategies referred to as "correspondence education", "correspondence study", "home study", "independent study", "distance teaching", etc.etc. The terminology of this informal education has been vividly described by the UNESCO in the following way:

"Education conducted by the postal services without face-to-face contact between teacher and learner. Teaching is done by written or tape-recorded materials sent to the learner, whose progress is monitored through written or taped exercises to the teacher, who corrects them and return them to the learner with criticism and advice."

This process of distance learning is so much easy, smooth and free from emarrassment or stiffness that all the working people who under unfortunate circumstances are unable to keep their feet on the threshold of institution, can adopt and accept it without hesitation and even with relaxed attitude.

It's our duty to inspire the illiterate masses, living in this ending century, to go ahead with this informal way of education. We are bound to get them fully convinced that their way of earning would not be bottlenecked. They are required only to devote a few hours at leisure time and can adorn themself with the light of knowledge which according to Aristotle is their natural desire and even inherited right. They are supposed not to kill it rather to go ahead. It is the prime need of the day as 20th Century is arriving with a number of challenges which people alone have to face and tackle, not the inferior elements of the universe.

Dr. Mahmudur Rahman
Editor

TOWARDS MORE EFFECTIVE USE OF COMPUTER RESOURCES IN DISTANCE EDUCATION INSTITUTIONS

by

KONRAD MICHALSKI

Centre For Distance Education, Athabasca
University, Canada

INTRODUCTION

This paper describes how to minimize capital expenditure, while at the same time maximizing the benefits of informational technology to students, faculty and staff of a distance education institution, might be achieved by reallocation of human resources and reprioritizing of tasks. One of the difficulties encountered in distance education is communication between geographically distributed students. The paper recommends how to improve the communication system among the students, as well as between them and the staff.

There have been different approaches to the use of computers by distance education institutions around the world. Mainframe computers were heavily used, and are still very popular. At the same time, the growing power of micro computers lowers the demand on the mainframe, and makes personal computers powerful enough to run previously mainframe-based applications. This paper deals with the ways of using the less expensive resources of mini and microcomputers.

The goal of this paper is to show alternative ways that will allow to:

- a) achieve better utilization of existing computer resources;
- b) make the distance education institution a more attractive place to study;

- c) improve student service quality;
- d) increase internal and external communication;
- e) better accommodate administrative needs.

EXISTING RESOURCES

This section traces the growth of computer resources at Athabasca University from 1985 (See Table 1, and Fig.1).

Summary of the existing resources:

- 200 MIPS (See Fig.2)
- 18 GB of disk space (See Fig.3)
- 450 MB of RAM (See Fig.4)

As well as these resources, Athabasca University has approximately 220 micro-computers (130 -XTs, 30-286s, 20 Ataris, 13 Apples, 10 laptops, and a number of 386s). The most highly utilized mainframe computers are the VAX 8820, VAX 785, and one of the AT & T 3b2/1000s. The VAX 8820 computer has been handling up to 100 concurrent users, the VAX 785 up to 40 users, and the AT & T 3b2/1000 a maximum of 8 users. Several Sparkstations are used for desktop publishing: the remaining are used mostly as single user workstations, or not used at all. Altogether there is maximum 130 concurrent users on all these computers. While some machines are working at or near capacity, many are under-utilized. Efficient utilization of this power may save money, as well as avoid expensive hardware upgrades of existing mainframes.

Athabasca University has owned a conferencing system (CoSy), which has been used successfully by many other institutions. Purchased a few years ago, CoSy has hardly been used. Other options are one of the micro-based bulletin boards RBBS-PC Caucus, also owned by the university.

Table 1. Computer Configurations at Athabasca University

Model	Qty	MIPS	Disk Space (GB)	RAM (MB)	Install.Date	Disposal Date
PDP 11/34	1	0.5	0.056	0.256	1985	Sep 1986
VAX 780	1	1	1.3	16	1983	Aug 1989
VAX 785	1	1.3	1.3	64	Fall 1985	-
VAX 8600	1	4.2	2.3	64	1986	Jun 1987
VAX 8650	1	6.2	3.2	64	Jun 1987	Jun 1988
VAX 8820	1	14	4.2	128	Jun 1988	-
VAX 2000	5	4.0	0.35	20	Oct 1988	-
SUN 3/160	1	3.5	1.3	16	Jul 1987	-
SUN 3/50	2	2	0.15	8	Jul 1988	-
SUN 3/150	2	3	0.15	4	Apr 1989	-
SUN 4/370	1	17	1.3	24	Nov 1989	-
SPARK Station	9	98	1.0	96	Nov 1989	-
3b2/1000-70	8	42	5.1	272	1-Jul 89 7-Jul 90	-
SUN 4/260	1	12	2.2	16	Nov 89	-
AT & T 6386E	5	3	0.675	40	May 88 Nov 88	-

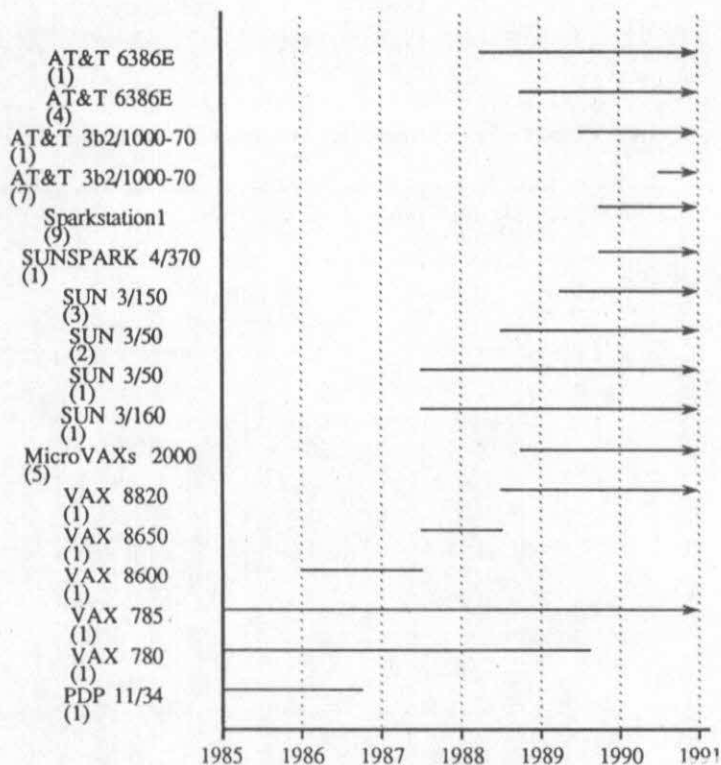

Fig. 1. Computer Installations at AU

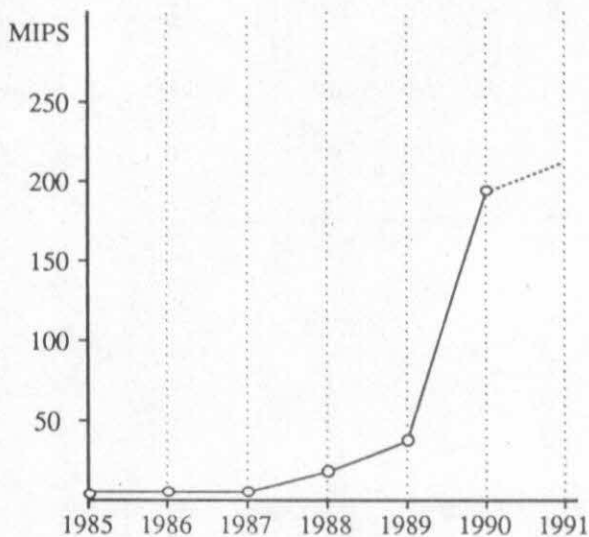

Fig. 2. Computer MIPS at AU

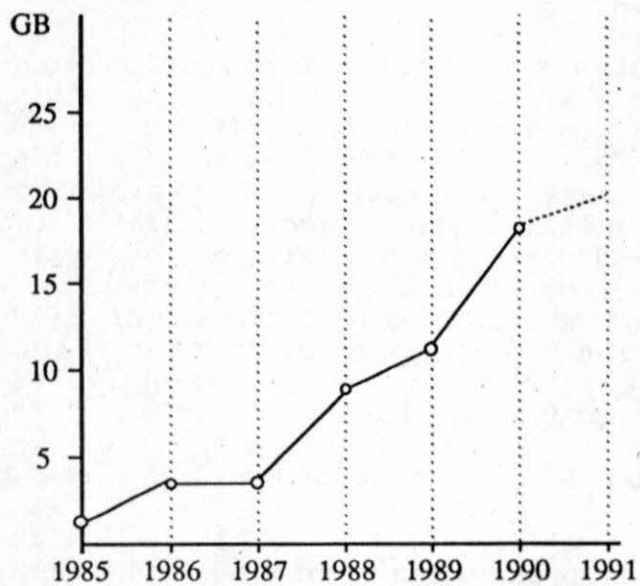

Fig. 3. Available Computer Disk Space at AU

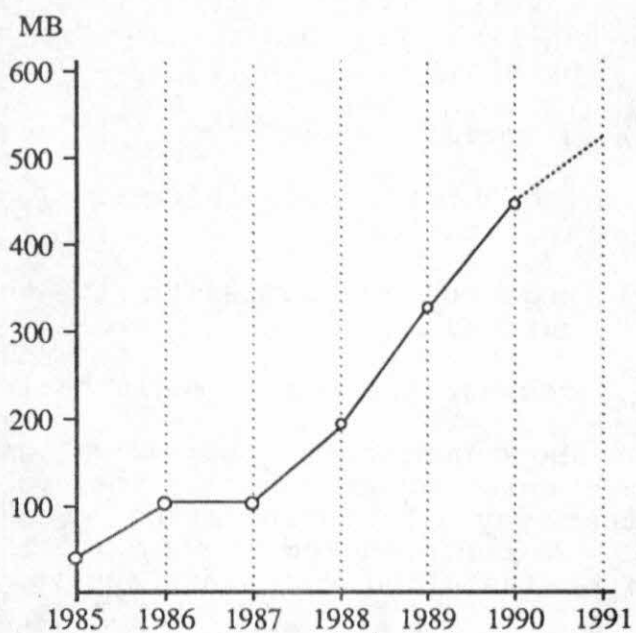

Fig. 4. Available RAM at AU

ON-LINE SERVICES

A distance education institution should allow the general public who own their own equipment to access an on-line service system remotely. This system would have a broad marketing impact, and would increase the number of registrations. The service quality and accessibility would be improved.[5] The system should be available to anyone with or without access to micros, or terminals, and modems. The information system could be installed using one of conferencing systems e.g. [19], or even less expensive PC based bulletin boards e.g. [6].

It would be recommended to have the following services:

- a calendar (catalog) on-line to allow the students and the general public obtain information about the institution;
- a bulletin board with daily announcements;
- institutional publications available on-line (in order to save money on prints).

Additional Services:

- request for more information about the institution;
- request for admission to the institution;
- request for course registration.

All above-mentioned services make the institution more accessible to the public, and open another way of communicating with the institution. A conferencing system or a bulletin board can be installed very inexpensively even on

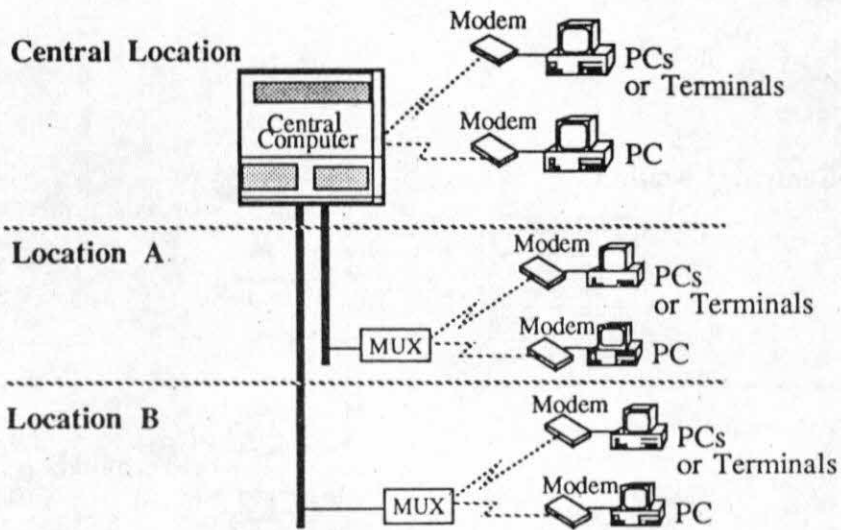

Fig. 5. The situation with lines from Location A and Location B to the Central Location allows anyone in the area with their own equipment to make inexpensive local calls.

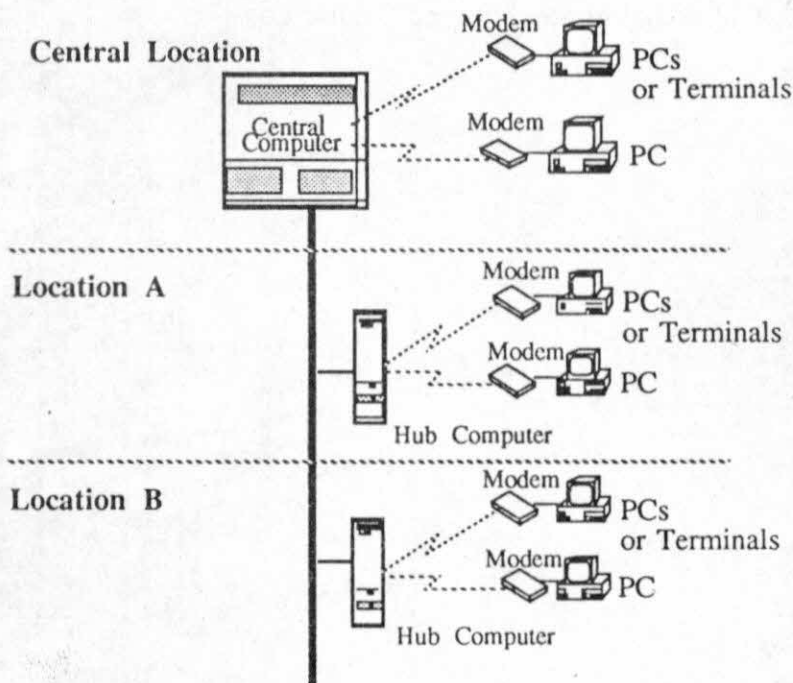

Fig. 6. The situation with hub computers in Location A and Location B the data distributed from the Central Location

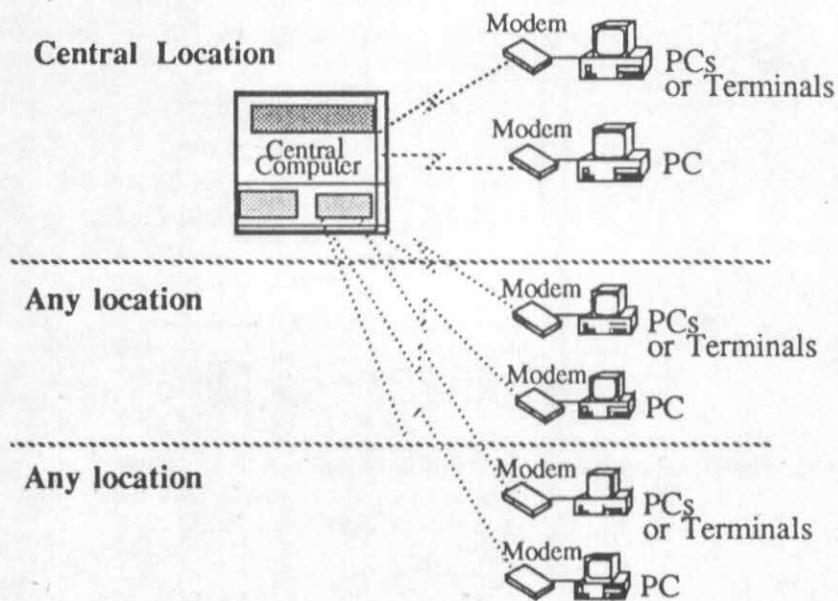

Fig. 7. Direct dial-in access to the Central Location

a micro computer. Few ways of setting up this service are shown on Figures 5 through 7. The selection of the service option depends on the situation of the institution, and its financial situation (e.g. Athabasca University has dial-in facilities in Edmonton and Calgary connected directly to the central computer located in Athabasca, and almost fifty percent of students are located in Edmonton and Calgary).

COMPUTER ACCESS FOR TUTORS AND STUDENTS

Many tutors and students own their own equipment, or have access to equipment, either at the workplace or other locations. Once the institution has its conferencing system or a bulletin board, they can be used as a platform to allow the communication between the students and the tutors. The communication costs are covered by callers, and different options are presented in Figures 5 through 7. One of the biggest difficulties of studying at a distance, is the isolation from other participants - students and tutors. This kind of computer access would decrease significantly the feeling of isolation, as well as facilitate study circles and new friendships via computers [23]. The students would be able to communicate not only among themselves, but also with their tutors. The students see high value in being able to communicate with other students [21], and as a result they could value the opportunity to establish different kinds of contacts on-line [5]. Computer conferencing systems and bulletin boards are available or virtually all computers, from mainframes to micros.

DISTRIBUTED (BATCH) DATA PROCESSING

Mainframe computers are powerful, and are designed to handle large numbers of concurrent users. Mainframe use is, however, much more expensive than other alternatives, especially in the areas of:

- software and hardware purchases;
- software and hardware maintenance.

Some of the institutions have the potential to avoid hardware upgrades of existing mainframes through proper utilization of the existing alternative power. The load of existing mainframes can be distributed to other existing mini computers, local area networks, or microcomputers, and to other under-utilized resources[24]. A feasibility study should be conducted to determine which applications or modules of applications can be distributed to other existing, not fully utilized resources.

The goal of distributing data processing is to:

- distribute the load evenly from overloaded computers to other, under-utilized ones;
- unload the mainframe to avoid expensive upgrades in the future;
- lower the costs of hardware and software maintenance;
- distribute the data and applications;
- create backup computers for key applications.

According to Skol [25], by staying on the mainframe MIS departments "will pay a high price in the form of relatively low productivity, less effective applications and continued unresponsiveness to end-user needs". The budget savings also are very extensive, not only in capital expenditures but also in human resources [16].

Connecting all the computers in a very tightly coupled network, generally makes them more vulnerable to problems associated with one of them going down. However, the computers can be connec-

ted in such a way that when one fails, the others can continue to work, even for extended periods of time (See Fig. 8a and 8b).

The following are guidelines for when and how data can be distributed or centralized [13].

Distributing Data:

- Data is used at one peripheral location, or belongs to one department;
- The accuracy, privacy, and security are a local responsibility;
- The files are simple and are used by one or few applications;
- The update rate is too high for a single centralized system;
- End users are involved in the manipulations, such as using end-user language, fourth generation language.

Centralizing Data:

- Data is used by centralized applications;
- Users in all areas need access to the current up-to-the-minute data;
- A high level security is required;
- The data is too big, or large database accessed by large number of users;
- Users of the data travel among separate locations;
- The data as a whole is searched;
- Mainframe software is needed (software which runs only on a mainframe).

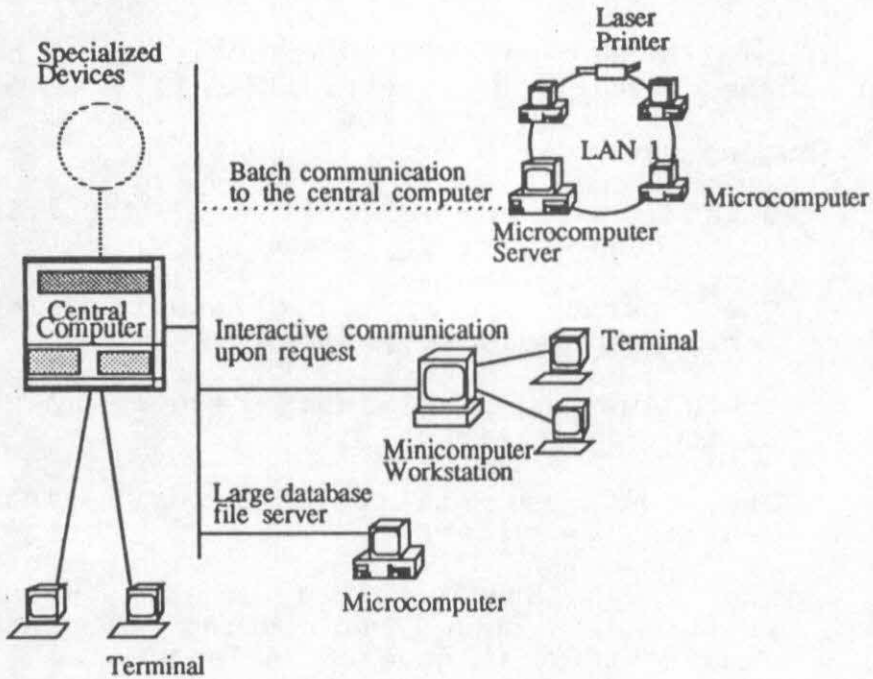

Fig. 8a. Distributed (Batch) Processing

Basic Functionality:

- A Central Computer goes down and remaining equipment (except directly connected devices and terminals) can function
- A LAN, a workstation, or a mini goes down and remaining LANs, minis, workstations, or a central computer can function

Specialized Devices

- high density tape backup
- high speed printer
- disaster recovery communication links
- archival system (ie. optical disks)

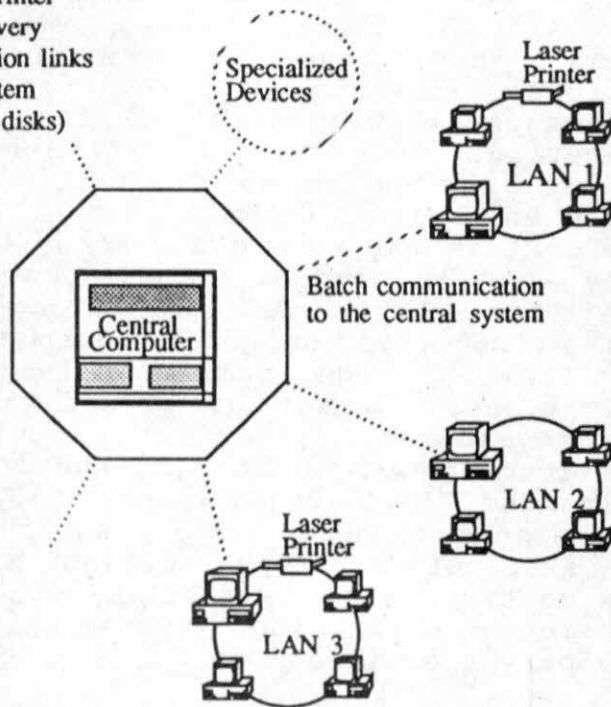

Fig. 8b. Distributed (Batch) Processing

NEEDS ANALYSIS

The needs analysis should always be done before any purchase or modification of hardware or software. The software and hardware are sometimes purchased without needs identification, analysis of impact on the department or users, or working out of all the details of implementation. Other problems that have occasionally arisen at educational institutions are related to modifications of existing stable systems without prior notification. Properly identified needs may save a lot of money and reduce frustration. Purchasing hardware and software without needs analysis is an almost certain way to wasting money by getting not exactly what is needed. The proper analysis may decide that the needs can be covered on the existing and under-utilized equipment (see previous item). The same applies to software modifications. A set of procedures based on a system development life cycle, should be used in the performance of these with the end-user always kept in mind [12,14,29]. Needs analysis is a part of the planning phase. The planning phase is the first step of a proper design process. The following steps are: feasibility study, functional requirements definition, system planning study, preliminary specifications [3].

Needs analysis should be done in the following steps: a) the requirements statement, b) functionality of the system, c) service level, d) mandatory, necessary, and desirable requirements. It should be emphasized that the above is not necessarily time consuming, and that initial planning will reduce implementation errors.

Alterations to the existing system are conducted in the following steps:

- Impact of changes should be explored, including consultation with users;
- A testing procedure, including the user, should be designed;

- Use of prototyping may be considered;
- If user procedures change, written user documentation should be made available;
- A schedule for implementation should be determined, and given to the user;
- Written procedures to be followed during implementation should be devised;
- Testing procedures begin after the system change has been implemented;
- A final report of the implementation should be written (including users' feedback, en-counterred errors, suggestions for the future etc...).

TECHNOLOGY IMPACT ANALYSIS

To succeed fully in an era of rapidly changing technology, the distance education institution is required to develop a strategic vision of how it can use technology to better achieve its goals. During the coming years, great changes in technology will occur rapidly. New technology offers new opportunities, new challenges, and unrecognized costs. We should be fully aware of all the critical changes in technology and the opportunities they present, so that we do not miss any of them [13]. A distance education institution needs to understand that technology and to plan how it can be used to achieve better results in both education and administration. A technology impact analysis should be conducted according to the following guidelines [12,13]:

1. Establish and prepare the team to conduct the analysis

The team may consists of a highly skilled in-house person, a qualified manager, and an external consultant. The team should have broad knowledge

of the institution, technology, and the industries.

2. Establish General Classification of New Technology

2.1) Technological changes:

Computers, workstations, networks, telecommunications, storage media (optical disk), data-bases, chips, software, security technology, print technology, video technology, artificial intelligence, tools and techniques, new applications, miscellaneous.

3. Business and Management opportunities

3.1) Marketing and international marketing

3.2) Services

3.3) Internal systems

Office automation, information systems, electronic training, selling excess processing power.

3.4) Decision making

Decision support systems, expert systems for decision making

3.5) Executive information systems

3.6) Supplies and inventory (e.g. just-in-time inventory control)

3.7) Production and products

3.8) Distribution

3.9) Alliances and partnerships

3.10) Growth

Broaden the student base, vertical and horizontal growth.

Some opportunities are available immediately and some will be in the future. A time-scale matrix should be developed to allow us to place the technologies in time [13].

- 0 - Immediate
- 1 - 1 Year away
- 2 - 2 Years away
- 3 - 3 Years away

The priority scale should be developed as well:

- Very critical - immediate implementation is needed;
- Critical - should be implemented with some urgency;
- Should be implemented with medium priority;
- Required, but with no urgency;
- Desirable, but not absolutely required.

CONCLUSIONS

This paper presents ways of utilizing existing computing resources, and of minimizing expenditures in distance institutions. The approach is to move from presenting alternatives for using existing or very inexpensive equipment, through showing how the existing resources can be utilized better, and more efficiently, to recommending how to do it right in the first place. The final recommendation is how to be ready for the future, avoiding the surprises and taking the opportunities it may bring.

There are recommendations for making the institution more attractive to students and the general public, by making its services more accessible for remotely located users. By relatively inexpensive use of some on-line services, the institutions may make its organization more effective, with faster turn-around, and very up-to-date information. Communication among students and tutors has always been a big problem for distance education institutions, and when combined with students' feeling of isolation is thought to be related to low completion rates. This paper suggests how to improve both.

The fast growing power of computer hardware, and the number of machines being purchased by the institutions, make them a perfect resource of additional computer power. With mainframes starting to look almost like "dinosaurs", some MIS departments still do not want to recognize that there is big power in those "toys" called microcomputers. Many users with very powerful 386 or 486 microcomputers use them only for word processing. Proper use of their power, by distributing data processing to other existing and under-utilized resources, may save money.

Proper utilization of existing resources or purchase of new ones should come as a recommendation from needs analysis. Some institutions seem to base their purchasing on somebody's very rough estimates, made for future, fuzzy, and non-quantified projections. They end up with enormous hardware power not being utilized, waiting for future use, which may never come.

The fast changing technology does not have to be unpredictable and spring surprises. By doing analysis of new technology, and using its advantages, the distance education institution will be prepared to challenge the future and win the battle.

REFERENCES

- Abbot R., *An Integrated to Software Development..* John Wiley & Sons, New York (1986).
- Beizer B., *Software System Testing and Quality Assurance*, Van Nostrand Reinhold Company, New York (1984).
- Critical Issues in Information Processing Management and Technology Vol 5*, QED Information Sciences, Inc., Wellesley, Massachusetts, 1989.
- Davis W., *Systems Analysis and Design a Structured Approach*, Addison-Wesley, Menlo Park (1983).
- Dirksen C. and Ostbye T., *Effective Computer Conferencing in University Education*, *Journal of Education for Business*, May 1989.
- Dvorak J., *Dvorak's Guide to PC Telecommunications*, McGraw-Hill, Berkely CA (1990).
- Edwards P., *Systems Analysis Design and Development with Structured Concepts*, Holt Rinehart and Winston, New York (1985).
- Fairley R., *Software Engineering Concepts*, McGraw-Hill, New York (1985).
- Fisher A., *CASE - Using Software Development Tools*, WILEY, New York, (1988).
- Gane C. and Sarson T., *Structured Sysrtems Analysis: Tools and Techniques*, Prentice Hall, Englewood Cliffs (1983).

- Jackson M., *Systems Development*, Prentice Hall, Englewood Cliffs (1983).
- Martin J., *Information Engineering - Book II Planning and Analysis*, Prentice Hall, Englewood Cliffs (1990).
- Martin J., *Information Engineering - Book III Design and Construction*, Prentice Hall, Englewood Cliffs (1990).
- Martin J. and McClure C., *Structured Techniques: The Basis for CASE*, Prentice Hall, Englewood Cliffs NJ (1988).
- Nordbotten J., *The Analysis and Design of Computer-Based Information Systems*, Houghton Mifflin Company, Boston (1985).
- Pastore R., *Turner rebuilds on PCs*, *ComputerWorld*, page 37 (April 15 1991).
- Peters L., *Software Design: Methods & Techniques*, Yourdon Press, New York (1981).
- Pinella P., *What PC Managers Need to Succeed*, *Datamation*, page 87 (September 15 1990).
- Quarterman J., *The Matrix - Computer Networks and Conferencing Systems Worldwide*, Digital Press, (1990).
- Rekkedal T. and Paulsen M., *Computer Conferencing in Distance Education: status and trends*, *European Journal of Education*, Vol. 24, No.1, 1989.
- Romiszowski A., *Computer Mediated Communication for Instruction: Use e-Mail as a Seminar*, *Telecommunications for Learning, Educational Technology Publications Vol Three* Page 52, Englewood Cliffs, 1991.

Ross S. and Smith L. and Morrison G.,
Helping At-Risk Children Through
Distance Tutoring, Research Bulletin
#3, MECC/University of Minnesota Center
for the Study of Educational Technology,
page 22 (June 1990).

Smith C., The educational value of
computer-mediated communications, Media
in Education and Development December
1988.

Shorrocks B., Microfobia - Disease of the
Eighties, Direct Access, page 9 (January
27 1989).

Sokol M., Mainframe programmers and V-8
mentality, Computerworld page 25, April
15, 1991.

Walsh R., Modern Guide to EDP Design and
Analysis Techniques, Prentice Hall,
Englewood Cliffs (1985).

Ward P., Systems Development Without Pain,
Yourdon Press, New York (1984).

Whitten J., and Bentley L. and Barlow V.,
Systems Analysis & Design Methods,
IRWIN, Homewood IL (1989).

Yourdon E., Modern Structured Analysis,
Yourdon Press; Englewood Cliffs (1989).

Yourdon E., Managing The system Life
Cycle, Yourdon Press, Englewood Cliffs
(1988).

PAKISTAN JOURNAL OF DISTANCE EDUCATION

Volume — X

1993

Issue — I & II



Allama Iqbal Open University
Islamabad — Pakistan

THE LEVEL AND RANGE OF SCIENCE
AND TECHNOLOGY COURSES AT
ALLAMA IQBAL OPEN UNIVERSITY ISLAMABAD

by

Dr. S. Attaullah Shirazi
and
Dr. Naseer Ahmed

1. Preview

Over the past few decades Distance Teaching has not only been a great help to promote and propagate general education to the masses, but has proved to be valid tool to accelerate the pace of Scientific and Technical Education also.

The demand for education i.e. general as well as science, is increasing day by day, especially in the Third World countries. However, the formal system, due to its own problems and constraints, has not been able to promote and extend Scientific and Technical Education to the extent to reach the public at large. The realization of the magnitude, complexity and pressure of the ever increasing problem has led more and more countries to turn to Distance Education as a solution.

Allama Iqbal Open University in Pakistan since its inception in 1974 has taken care of Science/Technology courses. Agricultural and Technological courses were included in the very first published scheme of AIOU course programme. The first functional non-credit course on Kitchen-Gardening was launched in 1977, with full radio and T.V. support.

Courses developed/launched by various departments of F/O, B & AS are discussed in this paper in relation to their level and range.

2. The Faculties & Departments

The University runs/launches its courses through the following three faculties:

Table-1: Faculties of AIOU

- | |
|--|
| <ol style="list-style-type: none">1. F/o Basic & Applied Sciences2. F/o Social Sciences & Humanities3. F/o Pedagogy, Adult Literacy and Continuing Education |
|--|

The first two faculties were established in 1982, and the third in 1984.

At present the F/o B.A.S. consists of the following six departments:

Table-2: Departments of F/o B.A.S.

- | |
|---|
| <ol style="list-style-type: none">1. Department of Agricultural Sciences2. Department of Basic Sciences3. Department of Technical & Vocational Education4. Department of Women Education5. Department of Maths, Statistics and Computer Sciences6. Department of Science Education |
|---|

All these departments have developed/offered courses in relevant fields at different levels.

3. Levels of ST Courses

At present AIOU offers various courses right from the grassroot level to postgraduate level. The titles of courses developed with in the Faculty of Basic &

Applied Sciences alongwith their level are given in table-3,4,5,6,7 & 8 at the end. Levels at which courses are offered are discussed below:

3.1 Postgraduate Level

AIOU has started offering its postgraduate courses since long. For example, EPM programme was first launched in 1976. However, at present various post-graduate programmes like EPM, MBA, TEFL, MSC Pakistan Stuides and M.Phil in Urdu, Iqbaliat, Education and Islamiat are run successfully.

As shown, in table-3, two courses namely "Business Maths & Statistics" (523), launched in 1986, and "Operation Research" (564), launched in 1988, have been prepared by the Department of Maths, Statistics & Computr Sciences. Both these courses are part of MBA Programme.

3.2 Graduate Level

With the beginning of graduate level courses in the AIOU the departments in F/o BAS had started developing science courses. So for two of the courses i.e. Business Math & Stats (421) and Food & Nutrition (428) have been launched at graduate level (Table-3). Many other courses are presently at various stages of development.

3.3 Intermediate Level

At this level, there are 25 courses offered by various departments of Science Faculty. The earliest being Food & Nutrition (306) and General Science (308) launched in 1979. The detail of these courses is given in Table-4.

Table-4 also indicates that out of these, four have been prepared by the department of Agricultural Sciences (S.No.1-4), one by the department of Basic Sciences (No.5), seven by three by the department of Women Education (S.No.13-15) and TEn by Maths, Statis-

tics & Computer Sciences Department (S.No.16-25), including eight courses being run in collaboration with the "PETROMAN".

Being newly set up, the department of Science Education has not been able to offer a course at this level so far.

3.4 S.S.C. (Matric) Level

Table-5 indicates the titles of the courses offered by various departments of F/o Science at S.S.C. level. It includes courses by Department of Agricultural Science, Women Education, Basic Sciences and the Department of Maths, Statistics & Computer Sciences.

3.5 Non-Credit (Functional Level)

Functional Education has an immediate practical value for the learners. All the courses in this category have been developed by the department of Agricultural Sciences. However, some of the courses of Department of TVE can also be taken as functional one. The list of the non-credit courses is given in Table-6.

The entry requirement for all such courses is only literacy. Almost all the courses in this category help the farming community in various ways and enable the learners to enhance their knowledge, skill and income.

3.6 Basic Level

The basic level courses are developed by various departments at the campus and then handed over to BUESP for offering in villages at various places in the country. The transfer of technology is carried out through cassettes, handouts, and flip charts to farmer groups, supervised by the field staff. Relevant Government and Non Government agencies/organizations are involved in the process of course development and presentation.

The programme is serving the village-learners

through transfer of technology since 1983. At present, there are 11 courses offered at basic level. Out of these, five have been developed by the department of Agricultural Sciences, five by department of Women Education and one by the department of TVE. The list of these courses is given in Table-7.

3.7 Newspaper Courses

Recently in 1988-89 AIOU started "Newspaper Courses" in collaboration with Pakistan National Press Trust. Except English, all the courses in this category fall under the field of Science & Technology.

List of these Science courses is given in Table-8. So for eight (8) such courses have appeared in various newspapers. The courses at this level have been developed by the deptment of TVE, Women Education, Agricultural Sciences and the department of Maths, Statistics and Computer Sciences. As indicated in Table-8, four of such courses are offered through Urdu newspapers, three through English and two through English and Urdu alike. The newspapers which publish these courses are Morning News (Karachi), Pakistan Times (Lahore, Islamabad), Mashriq (Lahore) and Imroz (Lahore).

3.8 Tutorial Support & Practicals for S&T Courses

Distance education and learning in the areas of Science and Technology, involves complex relationship between learners, the subject matter to be taught, the learning material and the course support to the correspondence element of S&T sessions. The department of Technical and Vocational Education made a successful start in 1979 by offering the Electrical Wiring (first technical course) and solving the logistical problems of practical work in S&T education. The expertise and experience obtained in this course were utilized/applied to other courses. The courses are designed around a text based learning package which is studied at home and is supplimented by the provision of face-to-face

tutorials at approved study centres.

For courses offered by Faculty of Basic and Applied Sciences, the students are required to attend study centres (usually schools, colleges, Technical Training centres and Polytechnics) for their face-to-face tutorials. At these centres the student carry out practical work and undertake practical skills assessment under the supervision of qualified tutors. In addition, they also benefit from the contact with both their tutors and fellow students through material discussions and consultations.

The activity/work book, have also been designed for some courses. The students are required to carry out the practical activities both at home and at study centres and complete the workbook. The tutors check and mark each practical activity in the activity/work book and these marks are included in the final examination.

The computer courses (Code No.901-908), offered in collaboration with the PETROMAN have a qualified teachers at various centres.

4 Range of AIOU S&T Courses

Keeping in view the nature of the academic departments in the F/o B.A.S. a wide range of courses has been developed. This allows and provides the students a fairly wide choice of subjects/courses. Some of these have been clustered together. However, the word 'range' could be defined in different ways for the purpose of this paper. For example, range could be explained as:

- a) range of courses according to the disciplines,
- b) geographical range of AIOU S&T courses, and
- c) range according to male, female students. For the purpose of this paper all the three aspects are discussed briefly.

4.1 Range of S&T Courses According to Disciplines

As already discussed, there are six departments. Each department develops the courses within its own domain.

Therefore, due to the different speciality of each department there is a wide range of disciplines covered by S&T courses already developed. The following list highlights the disciplines or areas which a particular department has covered so far:

Department	Disciplines
1. Agricultural Sciences	1. Crop Production 2. Live Stock & Poultry 3. Farm Machinery 4. Soils 5. Plant Protection 6. Credits
2. Technical & Vocational Education	1. Electronics 2. Auto 3. Electrical
3. Women Education	1. Nutrition 2. Family Health Care 3. Home Economics
4. Basic Sciences	1. Biology 2. Physics 3. Chemistry
5. Maths, Stats & Computer Sciences	1. Maths 2. Physics 3. Computer Sciences
6. Science Education	1. Science Education

It can easily be comprehended from the above list that AIOU S&T courses provide a wide range with a vast

and ample variety at the disposal of the students at the time of admission. Besides, people with very little education, or having a degree of high order, young or old, even retired persons, can easily find courses of their own interest. Perhaps, this facility, to such varying class of people, is not available in any other university of Pakistan.

4.2 Geographical Range of S&T Courses

Being an open university, AIOU has no geographical limits. Students from all parts of the country, even Pakistanis abroad can be enrolled in the courses/levels of their own interest.

At present, there are 32 regional and sub-regional offices, right from Ustore & Gilgit down to Lasbella and Zhob. These regional offices help and facilitate the students in their selection of courses, admission, workshops, tutorials and exams. Students can get all sort of information about AIOU, its system, courses, exams, etc. any time. This unique feature of the University has taken the university S&T courses to the door steps of learners all over the country.

4.3 Male Female Ratio of S&T Courses

As already discussed, like all other AIOU courses, S&T courses are also open for male and female students. Table-9 indicates the enrolment that the Department of Women Education enrolled 57% female learner enrolled by the department of Agricultural Sciences and Basic Sciences respectively. However, the female ratio for the Department of TVE, and M.S.C's being 2% and 9% respectively, is very low. This, perhaps, is due to the nature of courses offered by both these departments at present. In general, male female ratio in all S&T courses is 62:38, which is very encouraging, especially when the female literacy rate in the country is not more than 17 percent.

At the end, it would be appropriate to give a brief sketch of total enrolment i.e. number of students

so for enrolled in each department of the Science Faculty. Total enrolment of each department in the Faculty of B.A.S. is given in Table-10, which indicates that 166281 student have so far been enrolled in these courses up to Spring 1992.

Keeping in view the above discussion, it is clear that S&T courses are offered at all levels, available under the system and also these courses have a vast range of variety to motivate and facilitate the learner for enrolment, and are accepted by both male and female learners throughout the country.

Table-3 Postgraduate & Graduate Level

Level	Courses	Code	1st Presentation
1. Postgraduate Level (MBA)	1. Business Maths & Stats	523	Autumn 1986
	2. Operation Research	564	Spring 1988
2. Graduate Level	1. Business Maths & Statistics	421	Autumn 1984
	2. Food and Nutrition	428	Spring 1988

Table-4 Intermediate Level Science Courses

Courses	Code	1st	Presenta- tion
1) Dairy Husbandry	313	Autumn	1987
2) Improved Methods of Fruit Production	342	Autumn	1985
3) Improved Methods of Oil Seed Crop Production	328	Spring	1988
4) Farm Income Generating Skills	326	Spring	1989
5) General Science	308	Autumn	1979
6) Electrical Wiring	307	Autumn	1979
7) Electrician	314	Spring	1981
8) Maintenance and Repair of House Hold Electrical Appliances	341	Autumn	1986
9) Auto Servicing	332	Spring	1989
10) Basic Electronics	344	Autumn	1986
11) Auto Mechanics			
12) Radio Servicing	348	Autumn	1992
13) Food & Nutrition	306	Spring	1979
14) Child Care and Development	330	Autumn	1982
15) Home Management & Home Furnishing	345	Autumn	1989
16) Maths	323	Autumn	1988
17) Statistics	331	Autumn	1988
Computer Courses			
18) Computer Concept and Architecture	901	Autumn	1991
19) Programming with COBOL	902	Autumn	1991
20) Operating Systems	903	Autumn	1991
21) Application Software-I	904	Autumn	1991
22) Sysrtem Analysis and Design	905	Autumn	1991
23) Programming with 'C' Language	906	Autumn	1991
24) Application Software-II (Database Application)	907	Autumn	1991
25) Programming with Pascal	908	Autumn	1991

Table-5 Matric Level Science Courses

Courses	Code	1st Presentation
1. Poultry Farming	211	Spring 1988
2. General Science	203	Spring 1988
3. Selling of Home made Products	200	Autumn 1987
4. Garments Making-I	208	Autumn 1987
5. Garments Making-II	210	Spring 1988
6. General Home Economics	209	Autumn 1987
7. Family Health Care	206	Spring 1988
8. Maths	214	Autumn 1988
9. First Aid-I	217	Spring 1989

Table-6 Non Credit (Functional) Level

Courses	Code	1st Presentation
1. Vegetable Growing (S)	101	Autumn 1977
2. Vegetable Growing (W)	102	Spring 1977
3. Tractor Maintenance	106	Spring 1981
4. Soil Problem & their Remedies	103	Autumn 1978
5. Plant Protection	104	Autumn 1978
6. Poultry Farming	105	Autumn 1980
7. Sheep & Goat Husbandry	107	Spring 1988

Table-7 Basic Level Science Courses

1. Live Stock Management
2. Electricity in Village
3. Poultry Keeping at Home
4. Agricultural Credits
5. Child Care-I
6. Child Care-II
7. Sanitation
8. Knitting
9. First Aid
10. Better Yield (Barani Area)
11. Better Yield (Irrigated Area)

Table-8 Newspaper Level Science Courses

1.	Child Care (Urdu)
2.	Food & Nutrition (Urdu & English)
3.	Poultry Keeping (English)
4.	Motor Car Maintenance (English)
5.	Computer Literacy (Urdu)
6.	Garments Making (Urdu)
7.	Kitchen Gardening (Urdu and English)
8.	Sericulture (Urdu)

Table-9 Male Female Ratio of S&T Courses (Spring, 1992)

Faculty of Basic & Applied Sciences	Male	Enrolment		Total	
		Male	Female		
i) Department of Agricultural Sciences	1312	53%	1164	47%	2476
ii) Department of Basic Sciences	1040	47%	1173	53%	2213
iii) Department of Technical and Vocational Education	1183	98%	23	2%	1206
iv) Department of Women's Education	1109	22%	4024	78%	5133
v) Department of Science Education	-	-	-	-	-
vi) Department of MSCS	7283	91%	683	9%	7966
Grand Total	11927	62%	7067	38%	18974

**Table-10 Department wise Total Enrolment
upto Spring, 1992**

Faculty of Basic and Applied Sciences	Enrolment
i) Department of Agricultural Sciences	33548
ii) Department of Basic Sciences	23160
iii) Department of Technical and Vocational Education	38507
iv) Department of Women's Education	56410
v) Department of Science Education	-
vi) Department of Mathematics, Statistics and Computer Sciences	14656

REFERENCES

AIOU Ten Years Report 1975-1985.

AIOU Information Booklet Postgraduate Programme, 1989.

AIOU Taleemi Programme Spring, 1988.

AIOU Distance Education System and the role of AIOU, 1985.

AIOU Four Year Report 1989-1992.

Personal Communication with Director Research and Evaluation Centre.

Personal Communication with Heads of the concerned Department.

PAKISTAN JOURNAL OF DISTANCE EDUCATION

Volume — X

1993

Issue — I & II



Allama Iqbal Open University
Islamabad — Pakistan

INSTRUCTIONAL DESIGN PRINCIPLES DERIVED FROM
COGNITIVE PSYCHOLOGY: IMPLICATIONS FOR
DISTANCE EDUCATION

by

JOHN R. MINNIS

The purpose of the paper is to present relevant contributions from the research literature of cognitive psychology that provide insights into the design of instructional materials for adults. Guidelines for course design are derived from the literature and briefly discussed in terms of:

- (1) preparation of the learner,
- (2) language treatment,
- (3) mathemagenic aids, and
- (4) metacognitions.

Background

The fields of behavioral, developmental, social and cognitive psychology have contributed a set of learning theories to instructional design within a complex history of overlapping time lines. Certainly instructional design benefitted from the work of Skinner and his associates during its earlier years, although Skinner's work was an extension of prior, less applicable behaviorist research (Johnson, 1989: 3-15).

Behavioral psychology prevailed in most North American universities' psychology departments during the 1940s, 1950s, and 1960s and directly influenced early instructional design theories. Concepts such as reinforcement, contingency management, and behavior modification became popular throughout much of education, particularly at the K-12 level. More to the point, the concept that learning could be controlled and shaped, if not understood, by controlling the learning environment became central to many learning theories

and, by extension, influenced practitioners working with adults (Collins, 1987).

A major result of applying this behaviorist approach was the fairly widespread use of programmed instruction (PI). PI was characterized by specific and careful decomposition of the material to be broken into small "chunks". Learning each chunk, and being reinforced for this, eventually led the learner through the carefully constructed path of material until the whole of it was mastered. Among the lasting general contributions of behavioral psychology to instructional design is, in fact, the notion that large bodies of knowledge can be analyzed into component parts and recognized on the basis of a learning schema as opposed to a knowledge structure schema (Gagne, 1987:1-10).

However, two serious limitations of behavioral psychology led designers to look also to other branches of psychology. The first limitation was that behaviorism provided little guidance for more complex mental tasks—for example synthesis, analysis, or evaluation. The second limitation, and perhaps the more serious one from an adult education perspective, was that it appeared to treat both the learner and learning as passive. Current theory, in contrast, considers learning as active, energetic, and internally motivated (Hough, 1988:17-27; Gagne and Glaser, 1987: 49-83).

Many distance education programs at the post-secondary level which rely heavily on print-based

materials tend to overemphasize behavioristic recipes, such as: defining objectives in terms of conduct, breaking down learner tasks, setting specific achievement criteria, and providing student feedback by way of multiple assignments and tests.

These well-used devices are considered by Macdonald-Ross (1979) to be the "cultural descendants" of PI. They are found to be restrictive when applied to complex learning. The aim of this paper, then, is to review recent contributions of cognitive psychology research that provide alternative insights into the design process. A basic premise of the paper is that adult distance learners - in order to achieve a modicum of success academically - require certain dispositions or traits prior to the learning experience, such as: a fairly high level of reading ability, a relatively high and persistent motivation to read, and a fairly well developed capacity to plan and organize independent study projects (Coldeway, 1986:81-93; Powell, et al. 1990:5-19; Taylor, 1986:68-91). However, it is also well-known amongst distance educators that these predispositions to learning are not properly developed amongst the adult population generally, and that the entry skills of most learners is not adequately taken into account prior to their embarking on a study programme; hence the justifiable concern regarding attrition amongst distance educators and what to do about it. This is not to suggest, however, that such predispositions alone are the cause of attrition. On the contrary, research by Powell et al. (1990: 5-19) suggests that a sizeable amount of the variance of completion behavior is explained by predisposing characteristics. They do not, however, account for all of the variance; thus, indicating that predisposition is not, to use their terms, the same as "predestination". Powell and his colleagues go on to suggest that the interaction of institutional factors and changes in life circumstances along with predisposing factors, account significantly for the degree to which students experience "success" learning at a distance.

In view of the above, it would seem imperative that designers must assume a multifocal approach if they are

to assist students to be successful learners. While the literature recommends a multivariate approach to student success, i.e. focussing on the interaction of personal (dispositional) reasons for enrolment, institutional factors (pacing and delivery), and course design and delivery factors, the balance of the paper will emphasize the importance of designing materials so that reading, a key intellectual ability developed prior to engagement with a course of programme of study, can be stimulated and even further developed. Every aspect of the reading material must be considered: the sequence of presentation, the style in which it is written, the organization of content, the aids that can be developed and integrated into the design process to improve comprehension, and the clarity of layout of the printed page. These are the topics to be discussed below.

COGNITIVE RESEARCH AND THE DESIGN OF MATERIALS

Preparation of the Learner

One point of agreement amongst cognitive theorists is that the recall of prior knowledge improves comprehension and further recall (Gagne, 1978; Schallert 1982). Schallert calls this practice activation of existing schemas. Ways of invoking previous knowledge in distance learning materials have taken many forms. Some of the most commonly used devices are pre-test questions, summaries of theories or relevant facts, and rapid reviews of concepts and prior study material. Adults tend to remember those aspects of prose that are most meaningful and that fit in best with their current expectations. If, for example, a student's expectations have changed since a piece of material was read initially, then they tend to distort the content of the material in accordance with current expectations. Research indicates that in some studies, subjects believe that their plausible reconstructions and even their fabrications are accurate. Retrieval of information, then can be a highly active

process that is guided by plausible inferences. These inferences are based upon one's conceptual and semantic knowledge of the world (Wessels, 1982: 281-321).

Instructional designers ought to be aware that recognition and recall of information are two different yet related cognitive processes. They are related in so far as they are affected in similar ways by factors such as context and retroactive interference. Other factors, such as word frequency and complexity, may have negative effects on recall, which suggests that different processes undergird recognition and recall. To account for these differences, many theorists have proposed that recall involves two processes: generating items by searching through memory and recognizing items that had been presented by assessing their familiarity or their contextual associations. According to this model of retrieval, recognizing items requires the recognition but not the generation process. The model accounts for many observations, including the case of students that can recall words that they have previously failed to recognize (Wessels, 1982).

Retention, which is often the aim of learning, albeit a narrow one, in both recognition and recall procedures is influenced by retroactive interference and by the level at which information is processed. Another factor that affects recognition and recall similarly is the presence of contextual information both at the time of encoding and at the time of retention. Recall is facilitated by the presentation of cues. The same can be said of recognition (Wessels, 1982:180).

There are, however, variables that influence recognition and recall in opposite ways. One such variable is the frequency with which words occur in our language, as indicated by frequency counts in books and magazines (Kucera and Francis, 1967). In general, rare words are recognized better than common words, but just the opposite is true for recall (Kinsbourne and George, 1974). Similarly, rehearsing words in a nonelaborative manner often improves the level of recognition but has little effect on the level of recall (Mandler, 1979;

Woodward et al., 1973).

Another variable that affects recognition and recall differently is organization. Subjects who learn highly organized word lists recall more words than subjects who learn word lists that are not highly organized. On the other hand, the level of list organization has no discernable positive effect on performance in a recognition test (Kintsch, 1968; 1979). Some studies have shown that performance in a recognition test is affected by the level of list organization (Mandler and Boeck, 1974). Yet closer analysis has revealed that the effect of organization occurred when the subjects recalled the target items in the act of recognizing them. Thus it appears that organization influences recall, not recognition. Collectively, these research findings suggest that to some degree, different processes contribute to recognition and recall.

The implication for designers is that learners utilize similar yet related strategies in recall and recognition of information, and that getting the learner to simply recall previous study information through various instructional techniques is no guarantee that a meaningful connection between concepts has been made. For meaningful learning to take place, the learner must have relevant concepts available within their existing cognitive structure to which they can link the new material. For simple associations to be formed between concepts and words, they ideally ought to be presented very close together so that they can both be in the short-term memory at the same time and can then go forward into long-term memory (Lovell, 1987:55). It is possible for the association to be established as the result of one presentation but normally the more frequently the association has been repeated the more durable it is likely to be in long-term memory. When there is no meaningful learning to support the establishment of an association then plenty of repetition and revision are called for. With plenty of practice, material which is rote learned will stay in memory for long periods.

Language Treatment and Comprehension

Knowledge of the vocabulary being used in the text is an important yet overlooked factor for comprehension. In this regard, Stahl (1983) has shown that vocabulary instruction given prior to reading enhances comprehension. Other studies on the uses of verbal redundancy help students understand the ideas contained in the text, but should not be overused. The more an adult student knows about a subject, the more redundant additional readings on the same topic will be. The concept of staging device as used by McConkie (1977), which refers to the differentiation of two or more levels of importance in the text, can be used when course designers put the central idea of a paragraph at the beginning. More subtle forms can be thought of: to group all the sentences referring to attributes of an object in a paragraph, to use adjectives or phrases that denote importance when speaking about the point that has to be "staged", and some others. There is good evidence that all these elements improve retention too (Riche and Slater, 1983). In comprehending sentences and passages of prose, adults use their syntactic, semantic, pragmatic, and world knowledge in an interactive manner. The study of syntactic knowledge was first stimulated by Chomsky's linguistic theory, the theory of transformational grammar (1957; 1965) which concerns linguistic knowledge or competence, not performance. Chomsky proposed that linguistic knowledge consists largely of rules than can generate an infinite number of grammatical sentences. In his view, syntactic knowledge consists of phrase-structure rules and transformation rules. The phrase-structure rules produce the deep structure of a sentence, which specified important grammatical information such as what is the subject and what is the object. The transformation rules transform the deep structure into a surface structure which corresponds roughly to what we hear. Chomsky's work spurred the development of the field of psycholinguistics. Contemporary theories recognize that people process syntactic information in diverse ways through the use of strategies to fit the task, the type of sentence, and the listener's memory capacity.

In order to comprehend a sentence, readers must determine not only its literal meaning, but also its intended (deep structure) meaning. Determining the writer's intention is essential for integrating topically related information from different sentences in passages. Readers integrate information partly on the basis of their communicative or pragmatic knowledge, for example, the knowledge that the word she refers to an entity that had just been mentioned. The reader searches memory for a proposition containing the given information and then adds the new information to the memory representation. When the reader is unable to find in memory a proposition that contains the given information, he or she makes an inference that bridges the given and the new information.

The importance of world knowledge and experience is highlighted in recent research focussing on schema theories of comprehension. The field is new and evolving, but already there are findings which bear on instructional design. A schema is an organized framework of knowledge that describes objects, places, or episodes. A schema for eating at a restaurant, for instance, describes the sequence of events that occurs in eating at a restaurant - getting a table, ordering the food, and so on. Using the world knowledge embodied in the restaurant schema, one can make inferences about the events that probably occurred at a dinner that someone is talking or reading about. For example, the schema can be used to infer that the speaker examined a menu, even though the speaker never mentioned having done so. Further, listeners use schemata to form expectations about what the speaker is about to say. Thus, schemata contribute to the conceptually driven processing thought to be fundamental for comprehension. The research evidence indicates that comprehension and the recall of prose are facilitated when the reader uses an appropriate schema (see Wessells, 1982:311-315).

Schema theory has benefitted from a cross-fertilization of research drawn from computer science, linguistics, and cognitive psychology. Its practical utilization in design frameworks within distance

education have been so far limited. Its greatest potential no doubt lies in computer-assisted instruction and the application of other kinds of computer driven, interactive technologies.

Mathemagenic Aids

Mathemagenic aids, a term coined by Rothkopff (1982) refers to a series of devices used to activate thought processes with the purpose of enhancing learning. These include adjunct aids, questions, verbal directions, task demands, and other devices that perform mathemagenic functions. The most widely used aid of this kind is the advance organizer made famous by Ausubel (Ausubel and Robinson, 1969). In practice, a set of ideas are deliberately structured and presented to the learner prior to the material to be learned and comprehended. The advance organizer is intended to provide a conceptual framework that facilitates comprehension and retention by making available an organization of old, familiar ideas to which the new ideas/concepts can be related or anchored. In general, there are two types: expository and comparative. Similar to advance organizers are reviews (Marland and Store, 1982), but they differ from the former in the level of condensation of content. Reviews are written like the precis of the subsequent material. Their main purpose is to familiarize students with the scope and structural features of the material to be presented. They allow the student to "access the structure" of the chapter or book, for example, without reading the whole material. Reviews, in order to be effective, require a trained reader and one who has a certain familiarity with the material.

The use of adjunct aids has been investigated by Rothkopff (1982) in conventional instructional settings. Distance educators are usually less flexible in their ability to use these aids, but some elements that have been successfully used are: glossary of terms, list of cases or problems for application of the theory under study, short reading on a relevant topic but not related to the main purpose of the text, and so on. Adjunct questions can be used also. They are usually fairly

abstract and introduced during the process of reading in order to strengthen the recall of important information thereby influencing mathemagenic or reflective processes. One problem with this device in distance learning is that the student may skip the questions or just read them but not attempt an answer because they are too long. However, this can be remedied by setting procedures whereby some questions on examinations, for example, are related to the adjunct questions in the text. They can also be seen as tools to manipulate the disparity between the learner's current understanding of concepts and the desired understanding.

Research by Rothkopff (1982) and Marland and Store (1983) indicate that students do not always respond to instructional objectives in ways expected.

- (1) Students use objectives as selection devices to read information-sometimes incidental-that only has some resemblance with the objectives;
- (2) The effectiveness of objectives as selectors is inversely proportional to their number;
- (3) The effectiveness is related to the relative closeness of the objective to the content, and
- (4) Objectives are pathways to the structure of the text, when they are used as categories to divide the reading material into manageable entities.

Finally, a powerful technique for eliciting mathemagenic processes is the use of task demands or task structures (Rothkopff, 1982:120-2; McConkie, 1977:32-33). These are verbal requests made of the student to do something with the reading information. Examples are: case studies, complex exercises, instructions for doing summaries, comparisons, and critiques. If organized properly and used propitiously, such techniques can assist in the formation of healthy

learning habits. It is important for the skills that are involved effective learning not only to be learned, but to be used and repeated until they become habitual. This is essential if a person, especially an immature one or one whose educational background is not characterized by success, is to continue to use newly acquired skills in the future, or to apply them to new tasks that are not identical to those in which the skill in question was originally gained. The reason is simple: when things get difficult we tend to fall back on actions which are tried and tested, familiar and comfortable, and which we may perform with a degree of automacity. We avoid activities that are relatively unfamiliar, not so well-tried, and which demand all our concentration.

As Ramsden (1987) remarks, it is sometimes "intelligent" for a smart student to adopt a surface rather than a deep approach to learning. Newly-learned strategies are soon dropped, even when the user has been able to observe their effectiveness, if there has been no opportunity for the kind of practice that leads to such strategies becoming habitual (Belmont and Butterfield, 1977). Typically, it is much easier to teach a useful new learning or memory strategy than it is to ensure that people are able to go on using it.

Metacognitions

To what extent can knowledge of the reading process and strategies, by itself, improve one's reading effectiveness? If a student can be made aware of how their memory functions, how they make inferences, how their attention determines what they get from the text, can they be reasonably expected to become better readers? Research suggests the answer is yes (Anderson and Armbruster, 1982). However, it is difficult to introduce strategies related to the development of metacognitions of distance learners. Courses on study skills are not particularly effective, if used at all, in distance education. Perhaps the reason is that they are separated from the mainstream programmes of the institution. A feasible solution in this regard would

be to have a series of tasks included in the regular course materials, with the purpose of evaluating the processes used to learn. Questions could be addressed to such topics as what kind of outlines of the course structure were made by the student; what aspects of text generated more reflection, and so on. The student would then review these questions in order to diagnose potential or actual difficulties and then stress the practice of those reading techniques that could be more useful.

Student approaches to learning tend to be context-dependent. They vary within the same student between different tasks and are functionally related to students' perceptions of teaching and assessment (Ramsden, 1984; Laurillard, 1984). However, students bring to learning tasks their past experiences of similar situations; they have preconceived ideas of what makes for learning (Marton and Saljo, 1984). Saljo (1979) identified five qualitatively different conceptions of learning in interviews with adults that have implications for evaluation. Learning was seen as:

- (1) A quantitative increase in knowledge
- (2) Memorizing
- (3) The acquisition of facts, methods, etc; which can be retained and used when necessary
- (4) The abstraction of meaning, and
- (5) An interpretive process aimed at understanding reality.

Observed variations in approaches to learning are linked with variations in conceptions of learning at this more general level. Van Rossum and Schenk (1984) demonstrated that deep approaches were associated with conceptions 4 and 5 and surface approaches with conceptions 1 to 3.

It is of interest to note that Saljo's categories

reflect similar categories used to describe developmental processes in student learning, such as those in Perry's scheme (1970). The main distinction in Saljo's scheme between an absolutistic concern with facts as something separate from everyday reality and a plurilistic view of knowledge embodying the notion of alternative ways of understanding reality is close to Perry's contrast between dualistic thinking and relativistic thinking. Indeed, Gibbs, Morgan and Taylor (1984) have shown that students may shift during a programme of study from a less sophisticated to a more sophisticated conception of learning.

While instructional designers would probably agree that one of their tasks is to encourage students to develop more sophisticated conceptions of learning, it is difficult to assess how much development might be encouraged. So far little evidence has emerged from student learning research which bears on this question. A supportive teaching and assessment climate appears to be a necessary condition, at least for some students (Ramsden, 1984). Unfortunately, direct attempts to induce deep approaches may have the opposite effect from that which was intended (Marton and Saljo, 1976; Ramsden et al., 1987). Entwistle and Ramsden (1983), among others, have suggested that the teaching of metacognitive strategies in a form which draws attention to the existence of contrasting styles and approaches to learning which are idiosyncratic but effective, might prove to be advantageous. The increased use of study skill programmes concentrating solely on techniques, however, may help students to perform more effectively in certain assessments, but may be detrimental to the development of more complex conceptions.

CONCLUSIONS

The foregoing discussion has been offered as a picture, albeit incomplete, of some of the challenges facing instructional designers. First, we have tried to show the potential of cognitive research as a base for understanding the adult learner's educative needs.

Second, by implication, we have shown the limitations of behavioristic approaches which stress the conditions under which learning takes place to the exclusion of the mental processes that connect stimulus with response. Typically, a behaviorist asks "how much is remembered?" rather than "what are the qualities of what is remembered? So, when applied to distance education, behaviorism has led to theories of instruction rather than theories of learning. By contrast, cognitive models describe types of knowledge and so can be used to analyze subject matter and the interactive consequences of learning.

In spite of the brief discussion of techniques emanating from cognitive research, we should stress their underlying dimensions:

- 1) Relative amount of control over the learning.
- 2) Activation of Relationships; and
- 3) Level of text structure being processed.

The amount of control over the learner is given by the restrictions that the technique imposes on the decision made by the reader. There are highly obtrusive techniques such as staging devices, advance organizers, reviews, and lists of objectives; less obtrusive are task demands and adjunct questions. Activation of relationships refers to the amount of significant connections in the learner's cognitive structure that are elicited by the instructional device. There is low activation in vocabulary reviews, redundancy and staging techniques, but high activation in reviews, adjunct questions and task demands. The preference of techniques depends on the course content and the familiarity the student has with the content. Level of text structure being processed refers to whether the student grasps the surface structure of the text (passage), or the knowledge of deep structures. Techniques such as redundancy, staging devices and learning objectives that emphasize deep processing permit access to the knowledge structure.

If it is true that course design is now entering the "third generation" (Kaufman, 1989:60-78), characterized by computer-mediated communication, "openness", and a move toward greater participation and control on the part of the learner over their learning, then student's must have the ability to think critically, solve complex problems, and work independently of others-in addition to being computer literate. This means that designers must work even harder to enhance the quality of course materials as a means ensuring that such skills are developed. Research from cognitive psychology along with findings from information science research and management/engineering science, will likely continue to provide the theoretical bases of instructional design in the challenging years ahead.

References

- Anderson, T.H. and Armbruster B. (1982) Reader and textstudying strategies. In W. Otto and S. White (eds.) Reading expository material. New York: Academic Press, pp.21-32.
- Ausubel, D.P. and Robinson, F.G. (1969) School learning:an introduction to educational psychology. New York: Holt, Rinehart and Winston.
- Belmont, J.M. and Butterfield, E.C. (1977) The instructional approach to developmental cognitive research. In R.V. Kail and J.W. Hagen (eds.) Perspectives on the development of memory and cognition. Hillsdale, N.J.: Erlbaum; pp.4-29.
- Chomsky, N. (1957) Syntactic structures. The Hague: Mouton.
- _____(1965) Aspects of the theory of syntax. Cambridge, Mass.: M.I.T. Press.
- Coldeway, D.O. (1986) Learner characteristics and success. In I. Mugridge and D. Kaufman (eds.) Distance education in Canada. Beckenham, Kent: Croom Helm, pp.81-93.

- Collins, M. (1987) Competence in adult education. Lanham, Md.: University Press of America.
- Entwistle, N.J. and Ramsden, P. (1983) Understanding student learning. London: Croom Helm.
- Gagne, E.S. (1978) Long term retention of information following reading from prose. Review of Educational Research, 48, 4 (Fall), pp.629-625.
- Gagne, R.M. (1987) Introduction. In R.M. Gagne (ed.) Instructional technology: foundations. Hillsdale, N.J.: Lawrence Erlbaum Associates, Publishers, pp.1-10.
- Gagne, R.M. and Glaser, R. (1987) Foundations in learning research. In R.M. Gagne (ed.) Instructional technology: foundations. Hillsdale, N.J.: Lawrence Erlbaum Associates, Publishers, pp.49-84.
- Gibbs, G., Morgan, A. and Taylor, E. (1984) The world of the learner. In F. Marton et al (eds). The experience of learning. Edinburgh: Scottish Academic Press, pp.150-175.
- Hough, M. (1988) Motivation of adults: implications of adult learning theories for distance education. Pakistan Journal of Distance Education, vol. V, I, pp.17-28.
- Johnson, K.A. (1989) The foundations of instructional design. In Johnson, K.A. and Foa, L.J. (eds) Instructional design: new alternatives for effective education and training. New York: Macmillan, pp.3-15.
- Kaufman, D. (1989) Third generation course design in distance education. In R. Sweet (ed.) Postsecondary distance education in Canada. Athabasca, Alta.: Athabasca University Press, pp.61-78.
- Kinsbourne, M. and George, J. (1974) The mechanism of the word-frequency effect on recognition memo-

ry. Journal of Verbal Learning and Verbal Behavior, 13:63-69.

Kintsch, W. (1968) Recognition and free recall of organized lists. Journal of Experimental Psychology, 78:481-48.

Kintsch, W. (1979) Reading comprehension and readability in educational practice and psychological theory. In L. Nilsson (ed.) Perspectives on memory research, Hillsdale, N.J.: Erlbaum, pp.329-365.

Kucera, H. and Francis, W.N. (1967) Computational analysis of present-day American English. Providence: Brown University Press.

Laurillard, D.M. (1984) Learning from problem-solving. In Martin, F., Hounsell, D.J. and Entwistle, N.J. (eds.) The experience of learning. Edinburgh: Scottish Academic Press.

Lovell, R.B. (1987) Adult Learning. London: Croom Helm.

Mandler, G. and Boeck, W. (1974) Retrieval processes in recognition. Memory and Cognition. 2:613-615.

Mandler, G. (1979) Organization and repetition: organizational principles with special reference to rote learning. In L. Nilsson (ed.) Perspectives on memory research; essays in honour of Uppsala University's 500th anniversary. Hillsdale, N.J.: Erlbaum, pp.293-327.

Marland, P.W. and Store, R.E. (1982) Some instructional strategies for improved learning from distance teaching materials. Distance Education. 3, 1, pp.72-106.

Marton, F. and Saljo, R. (1976) On qualitative differences in learning: outcome as a function of the learner's conception of the task. British Journal of Educational Psychology. 46:115-127.

- McConkie, G.W. (1977) Learning from text. Review of Research in education. 5, pp.3-41.
- McDonald-Ross, M. (1979) Language in texts. Review of educational research. 6, 4, (Fall): 134-147.
- Perry, W.G. (1970) Forms of intellectual and ethical development in the college years: a scheme. New York: Holt.
- Powell, R. Conway, C. and Ross, L. (1990) Effects of student predisposing characteristics on student success. Journal of Distance Education, Vol.5, -no.1, pp.5-19.
- Ramsden, P. (1984) The context of learning. In Marton et al. (1984).
- Ramsden, P. Beswick, D. and Bowden, J. (1987) Learning processes and learning skills. In John T.E. Richardson, Michael W. Eysenck David W. Piper (eds) Research in Education and Cognitive Psychology. Milton Keynes: Open University Press, pp.168-178.
- Ramsden, P. (1987) Learning skills, or skill in learning? In John T.E. Richardson, et al. (eds.) (1987), pp.155-167.
- Riche, G.L. and Slater, W.H. (1983) Predicting learning from the text. Journal of Reading Behavior. 15, 1, pp.43-56.
- Rothkopff, E. (1982) Adjunct aids and the control of mathemagenic activities during purposeful reading. In W. Otto and S. White (eds) (1982), pp.47-69.
- Saljo, R. (1979) Learning in the learner's perspective: some common sense conceptions. Reports from the Institute of Education, University of Gothenburg, No.77.
- Schallert, D.L. (1982) The significance knowledge: a synthesis of research related to schema theory.

- In W. Otto and S. White (eds.) (1982), pp.134-167.
- Stahl, S. (1983) Differential word knowledge and reading comprehension. Journal of Reading Behavior, 15,4,pp.33-46.
- Taylor, J.C. et al. (1986) Student persistence in distance education: a cross-cultural, multi-institutional perspective. Distance Education. 7(1), 68-91.
- Van Rossum, E.J. and Schenk, S.M. (1984) The relationship between learning conception, study strategy and learning outcome. British Journal of Educational Psychology. 54,pp.73-83.
- Wessells, M.G. (1982) Cognitive psychology. New York: Harper & Row.
- Woodward, A.E., Bjork, R.A. and Jongeward, R.H.(1973) Recall and recognition as a function of primary rehearsal. Journal of Verbal Learning and Verbal Behavior, 12:608-614.

PAKISTAN JOURNAL OF DISTANCE EDUCATION

Volume — X

1993

Issue — I & II



Allama Iqbal Open University
Islamabad — Pakistan

**The Contributions of Asian Open Universities in
Moderating the Rising Cost of
Higher Education**

by

M.K. Bacchus

This is originally a report on the World Bank Seminar on Open Universities in Asia which was held in December 1992 in Madras, India. The aim of the seminar was two-fold. First, it attempted to look generally at the problems faced by the developing countries in trying to accommodate the increasing social demand for higher education particularly through their Open Universities. Secondly, the cost-effectiveness of the open universities was thoroughly examined and discussed, especially in comparison to the conventional universities.

The individuals invited to the conference were the senior staff of Open Universities in India, Sri Lanka, Thailand, Pakistan and Bangladesh. In addition, papers were presented on open universities in Indonesia and Hong Kong. Unfortunately, because of the difficult relationships that prevailed at the time between the host country and Pakistan, the selected representatives from the latter country did not attend the conference.

The co-sponsors of the seminar were the World Bank, the Commonwealth of Learning Headquartered in Vancouver, and the Indira Gandhi National Open University (IGNOU) of India. The Canadian International Development Agency (CIDA) which provided financial help to some individuals to participate in the conference was also represented--by the author of this paper.

The Vice Chancellor of Anna University which hosted the conference, stressed in his opening remarks the need for those engaged in providing and financing higher education to recognize the interdependence between the open universities and the conventional universities since they are both engaged in complemen-

tary aspects of the same task i.e. meeting the higher level human resource needs of a nation. He, therefore, suggested that greater links between these two types of institutions must be developed and expressed the hope that the discussions dealing with the cost effectiveness of the open universities might also benefit conventional universities in the region.

The Vice Chancellor of the Indira Gandhi Open University drew attention to the fact that since the 1980s there has been a substantial but recently decreasing rate of expansion of higher education throughout the world including Asian countries. But, despite the increase in student enrolment, the types of the programmes offered by many universities have virtually remained unchanged.

Further, in India the participation rate in the universities was still only 6% of the 17 to 21 age group and 80% of the student enrolment in the conventional universities was still drawn largely from the top socio-economic groups comprising less than 20% of the population. This left many other sub-groups with little access to post-secondary education, and it was against this background that the issue of social demand for higher education in Asia has to be considered.

But, largely because of cost, the continuing demand for higher education can no longer be met by the conventional universities alone. The recognition of this fact has probably led to the recommendation that in India each State should eventually have an open university. This increasing and broadening demand for higher education, therefore, makes it necessary for the current and proposed open universities to concentrate their efforts on human resource development among individuals throughout the whole spectrum of the society, particularly those already in the labour force.

In some Asian countries like India, there are now in existence three types of university institutions with facilities for distance education delivery systems emerging. These are (i) the open universities (ii) The conventional universities with correspondence departments and (iii) conventional universities offering some of their courses through distance delivery, usually in cooperation with existing open universities.

The Higher Education Specialist of the World Bank drew attention to the fact that, contrary to popular belief, the Bank was concerned about and heavily involved in supporting higher education, as it was with other levels of the educational system. For example, of the \$20 billion which it spent on education over the past decade, more than 20% of the allocated amount was devoted to higher education. Because of its concern for higher education, the Bank has been involved in organizing series of workshops on higher education in different parts of the world, including the current one.

The World Bank's representative also noted that the open universities are playing an important role in democratizing access to higher education and have contributed to the continued increase in enrolment at this level of education, especially since the 1980's. In addition, he emphasized the contribution by the open universities towards upgrading the level of knowledge and skill of those currently in the work-force. These institutions are, therefore, becoming key players in the continuing education efforts of many societies. Further, this is being done at a cost which is affordable and through a means of delivery that makes their instructional programmes accessible to large sections of the population, even those in the more remote and rural areas.

The Chairman of the University Grants Committee of India and a former Vice Chancellor of the Indira Gandhi

Open University also stressed the importance of establishing links between the open universities and the conventional ones, especially as the former extend their mandate towards developing instructional programmes in the technological and scientific fields.

He noted that the two focal topics selected for discussion at the seminar -- accommodating social demand for higher education and cost-effectiveness of higher education -- were important and timely ones, since the financing of higher education is currently under pressure throughout the world, even though the demand for this level of education continues to increase. He then proceeded to identify a number of questions which he thought might come under consideration by participants of the seminar.

Foremost among these was the issue of whether the provision of higher education should be mainly oriented to the economic needs of a country. Implicit in this question was whether "manpower needs" should be the only criterion for providing higher education facilities for a population. On this point he noted approvingly that the open universities in particular have been making special efforts to provide educational opportunities for disadvantaged and other groups which, for one reason or another, did not have the opportunity of receiving such an education in the past.

In connection with the issue of cost-effectiveness, he suggested that for many reasons, it might be inappropriate to make comparisons between per capita costs of students attending conventional universities and those studying through the open university system. In his view, such an approach is likely to reinforce the attempts by some open universities to replicate the programmes and activities of the conventional universities in order to emphasize the point that they can be more 'cost-effective' than these universities in offering comparable programmes. This type of focus

could stifle their creativity and restrict the effort of the open universities to become complementary rather than substitutive institutions to the conventional universities. This is likely to deny them an opportunity to make their own significant contributions to higher education and thereby lose the chance of developing a 'personality' of their own.

Finally, the point was also stressed that open universities, in their efforts to be cost-effective, should not lose sight of the more intangible but nevertheless important attribute of any good programme of higher education, i.e. the quality of the education that they provide, which is not always synonymous simply with the production of 'good' instructional materials at low prices.

The Minister of Education for Tamil Nadu drew attention to the importance of knowledge as a key resource in the development of today's societies. His view was that human resource development must increasingly be a matter of crucial concern for every government in the region. With the rapid proliferation of knowledge, this importance of its transmission, especially at the university level needs to be fully acknowledged.

But to ensure that this was done in an affordable manner, the mode of delivery of that education will have to be transformed and was already being transformed through the use of technology. This makes it possible to develop a new strategy aimed at making education available to larger sections of the society--one in which it was no longer necessary for people to be brought to an institution which provides them with this knowledge. Instead, it was one which would allow this knowledge to be transmitted increasingly to the population wherever they happen to be located and this was going to be a key role for, and the main contribution of, the open universities.

A point that was reiterated during the seminar was the increasing importance of knowledge as a resource one which he felt could compensate for the inadequacy of natural resources in the economic development of a society. This has led to the continued demand for higher education, not only among those leaving secondary schools but also those who were already in the work force and keen to upgrade their skills in order to ensure that these were up to date.

This along with the growing desire for equality of educational opportunity up to the highest level of the educational system, set against a situation in which there are declining financial resources for education has presented a challenge for more cost-effective delivery systems of education--one which goes beyond that of the regular face to face contact between lecturer and student -- the characteristic feature of conventional universities.

These developments have led and will continue to lead to a growing importance of open universities since, due to their greater flexibility than the conventional universities, they are likely to be in a better position to deliver higher education services to meet the needs of a variety of personnel and at a lower per capita cost.

Policy Issues for Aid Agencies in Providing Assistance for Open Universities in Developing Countries

There is no doubt that governments in many developing countries are becoming more interested in the establishment of open universities. Their aim is to help meet the growing demand among their population for higher education at a more 'reasonable' cost than that of the conventional universities. In these efforts many governments of the developing countries are likely to seek the assistance of aid-donating agencies and as a result the funding organizations need to attempt to

clarify their own aid policies in relation to open universities in the developing countries.

Among the issues to which attention needs to be directed are the following. Many developing countries are, as indicated above, seeing the open universities as a means of responding to the continuing increase in the "social demand" for higher education because of the lower per capita costs, involved in providing it, especially in the non-scientific and technical fields. But, despite the lower costs of producing Arts, Social Science and Law graduates through distance delivery, the countries providing these opportunities still have to ask the question as to whether increasing the supply of individuals with these qualification is likely to yield enough returns to justify even the lower level of investment made on their education.

The questions which therefore arise are: Should the open universities in the developing countries of Asia and elsewhere be more selective in the programmes which they provide?. Secondly, should aid donating agencies be prepared to provide financial support for open universities, irrespective of the value of the programmes which they provide for the economic and social development of these countries?.

Apart from the expenditure involved, a major concern must be whether an increased supply of Arts, Social Science and Law graduates is likely to result in increased number of individuals who are unable to find jobs that will utilize the skills and knowledge which they have acquired in the course of their studies?. If these highly educated individuals are unable to find jobs, particularly in the private sector -- since there is a tendency nowadays for most countries to down-size their public sector--are they likely to exert pressure for the public sector to be again expanded in order absorb them?. This is not an unusual phenomenon in some Asian countries like Pakistan. And are these governme-

nts likely to respond positively to these pressures in an attempt to ward off possible social unrest which such graduates might create, if they remained unemployed?.

Further, even if a limited number of jobs requiring a higher level of education became available, another question which arises is whether employers are more likely to seek their recruits from their traditional sources i.e. the conventional universities rather than employing those who have graduated from the open universities which have not yet acquired and might never acquire the social prestige of the older conventional universities.

To overcome this problem, the view might be advanced that if open universities are operated on a full cost recovery basis, students will soon realize that there is an already saturated market for individuals with certain types of qualifications and, therefore, shift their academic choices to other areas of study which might be in greater demand in the society. But, there are a number of problems which arise out of this expected development.

For open universities to operate on a full cost recovery basis, they will probably have to depend, in the development of their instructional programmes, on using "off the shelf" courses, which have been developed for similar institutions in other countries, as is done by the Open Learning Institute of Hong Kong. These courses are not always likely to be suitable or entirely relevant to the needs of the students of the country in which they are being utilized. But, students might be willing to use them simply as a means by which they are able to obtain their degrees, irrespective of the usefulness to their societies of the knowledge and skills which they might have acquired from their course of study.

Another potential area of savings is for the open universities to reduce their support services to more affordable levels. But, this is likely to cause a further decline in the quality of the education which self-financing institutions attempt to offer.

Finally, even if the open universities shift their efforts towards producing more science and technology courses and charge full cost fees the poorest students are likely to continue to opt for the cheaper Arts/Social Science/Law degrees, irrespective of the market signals. The reason for this is that the cheaper higher education courses might be all they are able to afford. This experience would be similar to that of the Blacks in the USA who have continued to invest in more higher education, despite the lower rates of return which usually accrue from their investment. With a lack of other capital resources, they see an investment in any affordable kind of higher education as the only means open to them through which they might try to improve their economic and social status.

Therefore, to repeat a point made earlier, the first question which faces by an aid-donating agency is; "Should it provide financial assistance for open universities that are simply responding to the social demand of the population by providing degree programmes in areas in which the graduates might have difficulty in finding jobs? Or should they provide targeted help to foster the development of specific programmes which are likely to produce trained individuals with more marketable skills--even though their courses might require a greater initial investment and even continued government subsidies to produce?.

Another question is; "Should more assistance be provided to open universities which focus their efforts on trying to improve and update the skills of

- a) individuals already in the job market? (The

return on this type of investment are likely to be more immediate and quite high.)

- b) Special groups who have so far been denied the opportunities for higher education because of their poverty, their location or other reasons--such as the scheduled castes and scheduled tribes in India, the rural population, women and other lower socio-economic and disadvantaged groups.

Finally, it should be noted that the establishment of open universities is not likely to have a great impact on the reduction of expenditure on higher education in the developing countries partly because of the share of their higher education budget spent on these institutions is small. Another reason is that open universities are often seen mainly as a means of extending higher educational facilities to additional numbers in the population, though at a reduced per capita cost, and not as a means of reducing the higher education budget.

However, one possible way in which open universities might contribute to a reduction in the expenditure on higher education in these countries is for them to work in collaboration with the conventional universities in developing their programmes. Some of these programmes then can be used by the regular students at the conventional universities--thereby helping to reduce both per student cost and the overall expenditure on higher education in these countries since their conventional universities absorb the largest portion of their higher education budgets.

Aid-donating agencies, might, therefore, want to consider providing financial assistance to those efforts aimed at producing programmes to be used jointly by the conventional and the open universities. The two types of institutions--the conventional and the open universities--working in cooperation with each

other are likely to help these societies grapple more effectively with the efforts at reducing higher education costs in the developing countries.

PAKISTAN JOURNAL OF DISTANCE EDUCATION

Volume — X

1993

Issue — I & II



Allama Iqbal Open University
Islamabad — Pakistan

Current Development in Distance Education*

By

Janet Jenkins

It would be hard today to find a country where distance education is not used. Thirty years ago the term had not been coined, twenty years ago it was a curiosity or a brave adventure, ten years ago a recognised educational alternative. Now it is becoming part of the mainstream of educational provision.

What forms does it take?

Open universities have led the way. You will be familiar with the development of large open university systems in Asia during the 1980s in countries including Thailand, China and India as well as in Pakistan. While Asia has become home to the largest open universities, there are others in the Americas, Europe and now also Africa as Tanzania is preparing to launch its national open university.

Open universities have given distance education a national and even international profile. But there have been other significant developments: at university level where a growing number of conventional universities offer distance education options; There are also Open Colleges, operating at pre-university level, and government or private institutions providing non-formal education for adults, and sometimes also for children, where out of school education may be offered; there has also been much development of distance education for continuing professional development for those already at work, such as teachers, nurses or those in business.

This growth has also meant change and diversification in the nature of providers. Open univer-

*An Open Lecture presented at Allama Iqbal Open University, Islamabad, on 9 November, 1993.

sities are normally under the wing of national Ministries of Education. Many recent developments, particularly those relating to continuing professional development, have been at the initiative of the private sector, with large companies or professional bodies starting distance education for training their own staff. Other developments may originate within other branches of the public sector, for example Ministries of Health or Employment.

The importance of distance education has been recognised in many cases at national level. Political change in, for example, former Eastern Europe and countries like South Africa and Namibia has been followed by interest in distance education as a means to assist rapid change. In other cases, governments see it as a mechanism to support ongoing development. In the last ten years, for example, Brazil has given distance education a place in its national legislation on education, India has assigned it high priority in its national education policy, and the newly ratified treaty of European Union - commonly known as Maastricht - contains a clause explicitly encouraging the use of open and distance learning for education and training.

Why has this change occurred?

In its first phase of development, the impetus came mainly from the pressure to expand access to formal education or its equivalent. Distance education was seen as a way of catering for more students, whatever the level. The UK Open University was originally intended to provide education for adults who had not been able to enter university as school leavers. Today, over twenty years since its foundation, demand still exceeds the places available. Other open universities have also since started with a concern to increase access, but with an additional or different slant - to provide a high quality alternative for school leavers, in countries where there is increasing demand for higher education but not enough places in conventional universities. Distance education is also seen as a means of expanding or improving schools. For

the benefit of school children, distance education is widely used for training teachers, both to increase the numbers of teachers and also to improve the quality of their teaching. And it is also used for out-of-school adults and children, with for example learning packages and television classes. So distance education is seen as a mechanism for moving towards the goal of education all.

A second thrust has been the recognition of the need for lifelong learning, particularly in the context of changing demands at work. In industrialised countries, it is estimated that every employed person needs to develop new skills and expertise on several occasions during their working lives, if they are to continue to contribute effectively to the economy. With conventional methods, an employer loses the services of the employee for the period of training. With distance education, the employee can stay at work and learn. As requirements for continuing professional development increase, so does the use of distance learning. It is very difficult to get a clear picture of the extent of its use, as there are so many providers in a variety of types of scheme. It is widely technical skills to management development courses. My belief is that iceberg like, most of it is invisible but larger than we could imagine. Could there be adequate provision of lifelong education and training for all without distance education?

Thirdly, the nature of demand is changing. Not only is the proportion of people demanding education increasing, but also both individuals and the economy require both a good general education and competence in a range of specific skills. The notion of "niche marketing", popular in business, has spread to education, with the idea that individuals need specialist provision of education and training. Conventional educational institutions seldom have the resources to offer the wide range of options needed. But if they introduce some distance education courses into their modular programmes they can do so. Many universities in Canada and Australia have operated in dual mode for

years, offering the same courses both on and off campus, with some provision for students to move from one mode to the other. For a while, this type of distance education seemed less attractive than the open university. Today there is a renaissance of dual mode and a broadening of the concept, with many more universities offering some distance education courses and introducing flexible options for switching between distance and conventional methods. Distance education enables greater choice with less resources.

Trends in provision

These demands have brought about an increase in numbers and types of institutions and bodies providing distance education. Perhaps the most noticeable is the number of higher education institutions that now offer distance education programmes. Look in any international business journal and you will see adverts for distance MBAs, many of them offered internationally. In Britain, although there is a national Open University, many universities also offer specialist distance education programmes. Many of these universities take this step with the minimum of internal rearrangement, perhaps one extra lecturer in a department and as administrator.

Another trend which is particularly apparent in Britain is the move towards making distance learning a component of normal college or university courses. Certain modules in a programme of study are offered by what we call open learning - you could describe this as the use of distance learning material in a flexible mode which involves both on and off campus study. More students. I make no apology for quoting Britain - I took part in a recent study undertaken for the OECD which indicated that the advent of this type of open learning, mixed mode in conventional universities, was a world-wide trend, best demonstrated in Britain. Some British universities have a policy that within a limited time - two or three years - a percentage of courses in all faculties must be offered by open learning. As a wider range of high quality learning

material becomes available it is likely that this trend will spread, and learners in conventional educational institutions will be given greater opportunities to control their own learning and select their subjects and even pace of study through the use of flexible open learning.

The most difficult issue for institutions moving in this direction is the management of this change. With the integration of open learning on quite a large scale, there are difficulties in determining the new role of academics, in providing the organisational infrastructure for open learning, and in the orientation of staff to take on these roles. Many British colleges - and it is interesting to note here that the colleges, for school leavers without university entry, led the way in these developments - and universities have Open Learning Units, centres for educational development or other units whose role is to facilitate this revolution in the practice of teaching and learning.

It may come as a surprise that distance education is now used in many small countries, in yet another way, it increases choice. Every country however small wants its own education system with its own institutions. But small countries some times do not have a sufficiently large pool of expertise to enable their educational institutions, particularly universities, to offer a full choice to their citizens. For a while, it was thought that distance education was too costly to provide an answer. Now it is realised that by sharing courses with other countries, distance education can help. The two federal universities in island communities, the University of the South Pacific and the University of the West Indies, led the way. They use audioconferencing facilities for the delivery of lectures and also to allow students from the various island nations to communicate with each other and with their lecturers. Now the University of the West Indies is looking harder at the role of distance education and how it might be possible to use it to expand provision. Some other national universities, such as the Univer-

sities of Mauritius and Guyana are also introducing dual mode, essentially based on materials developed elsewhere.

Such initiatives involve collaboration, an important trend. Some may be familiar with the Open Learning Institute of Hong Kong. The basis of its operation is to offer complete degree programmes largely compiled from courses purchased from elsewhere. In the first instance these came mainly from the UK, Australia and Canada. Such great importance was attached to the idea of collaboration and sharing that some six years ago the Commonwealth Heads of Government decided to establish the Commonwealth of Learning. Its aim was to foster co-operation and collaboration in education, making use of the opportunities offered by distance education and new technology. It has been instrumental in fostering various types of collaboration ranging from the more difficult joint development of courses to the more simple exchange and purchase. Allama Iqbal Open University (AIOU) has been involved in both these types of activity.

So the trend today is less to set up new autonomous distance teaching institutions, though there are some such as Bangladesh, and more to adapt existing institutions, often through collaboration and partnerships. There are now many groups and consortia. Interestingly the European Association of Distance Teaching Universities has amongst its 17 members only 5 fully fledged Open Universities, the other members being national centres or consortia representing over 150 conventional universities.

Changes in institutional arrangements

Open universities are changing in response to this new environment. The trend is to work with others in partnerships, at all levels where a university might be concerned, to develop outreach programmes. An Open University has specialist expertise to contribute to such partnerships, which may for example also involve conventional educational institutions and employers or

workplaces such as hospitals or schools. Some distance education institutions are also diversifying by encouraging the wider use of their materials in schools, colleges or conventional universities, or through selling materials only, without tuition, direct to private individuals. We also see distance learning materials packaged and available in a variety of contexts, making more learning opportunities for the public and creating added value for the providing institution. Flexibility and responsiveness of these large institutions has been greatly increased in cases where responsibilities have been devolved to the regions. There is thus a move towards greater integration of open universities with the rest of their national education systems.

Partnerships between education and business are now common in many countries. The European Union has given strong support to such partnerships, with two programmes in particular encouraging developments in open and distance learning: DELTA - Developing European Learning through Technological Advance - and COMETT - Community Programme for Education and Training in Technology. Many projects have been funded within Europe under these programmes. In order to ensure quality and provide models of good practice, projects are only funded if they meet certain criteria. Projects must be international, and normally should have partners from a variety of sectors. There has been a rapid broadening of experience in open and distance learning as a result of these initiatives.

New Technologies

Much recent development, including that supported by the European Union, can be associated with the breakthrough provided by the new technologies. The democratisation of information and communication technologies has had an enormous impact on all distance education. At its most basic level, word processors remove the drudgery from text development and production and make it possible to produce material faster and revise it more easily. Using desk top publishing,

it can be cost effective to reproduce a course in quite small quantities. Computer marking can remove the drudgery of much examination and assignment marking and, perhaps more important, guarantee a fast turn around time. Computers can also record and manipulate the mass of information needed to manage the complex processes handled within a large distance teaching institution.

At a more sophisticated level, it is fast becoming cheaper and easier to deliver learning to an individual distance learner using a personal computer. Both personal computers and software for them are now very powerful. There is not multimedia software, providing text, audio and video in interactive mode on one machine, which can run on a personal computer. While multimedia has not quite reached stage where it is within the price range of the average learner, it is possible to make these facilities available in centres where students may gather. Many such as office workers have computers in their workplaces. Some imaginative employers can see the value of allowing them to be used for training alongside work. For example hotel employees in Britain can follow French lessons in quiet moments on the same computers they use for hotel information. This example also shows the attractiveness of the medium in terms of flexibility and interactivity.

Professionalisation

With all these developments, many are now employed in the field of distance education. It is, therefore, no surprise to see that another trend is the professionalisation of distance education, accompanied by interest in staff development. There are several options available nationally and internationally of courses in distance education at diploma or Masters level, including a few taught at a distance. In addition, there are specialist short courses, such as that run by the International Extension College. At the Commonwealth of Learning (COL), I was responsible for developing policy and strategy for COL support for

staff development in the area of distance education throughout the Commonwealth. The position we adopted was that it was best done on a regional basis, and we started on a process to support the development of regional capacity in training. This was complemented by exchanges and fellowships between countries, and this university has drawn considerable benefit from this programme through workshops on instructional design for audio-visual media. This strategy depended for its success on widespread recognition by distance teaching institutions that professional development in distance education should have priority. Now the demand for training in most countries is very great, many major institutions have agreed induction and continuing professional development programmes for their staff, and use training materials which may be their own, purchased from elsewhere or adapted from those of others institutions.

Quality assurance

While distance education in general now has credibility, each particular course must compete against its rivals and demonstrate its quality. Staff development is often seen as an essential component in ensuring quality. Extensive debate on the issue of quality in distance education has focused on the need to pay attention to all components of the teaching and learning system. Institutional quality assurance arrangements are likely to cover design and operation of systems, the learning materials, their delivery, staff development; review, testing, evaluation of materials and of delivery systems; monitoring and feedback.

Quality assurance is important in any circumstances, but an imperative in the new climate of collaboration and interchange. If institutions are to use or recognise each others courses then there need to be common standards as well as provision for equivalence. The European Union has been particularly active in this area, because of the interest in transnational operation of distance education, and has developed some

useful guidelines on quality in distance education.

Issues and challenges

Growth in distance has been phenomenal, and it is not easy to identify the areas in which success is most significant. Judging by the extent of provision, programmes in management have done remarkably well. No doubt this is partly due to demand, but continuing and growing demand is in itself a measure of success. When one considers the extent to which management training involves interpersonal interaction, discussion and practical application, its success in the distance mode, which can be weak in precisely these areas, is of great interest. A study of why distance education in this area is proving so effective appears to be overdue.

Another area which needs further study is costs. As distance education first became popular, it was often sold to governments on the argument of its cost effectiveness. More learners could be taught more cheaply than by conventional means. It is now recognised that this argument could be misleading. Though cost effectiveness is of critical importance, it is not necessarily achieved by large numbers. The issue is by no means simple. Quality may sometimes suffer if costs are cut too far, large schemes are not always what is needed, reaching marginal students may be essential though costly. The issue of the costs borne by students is often overlooked.

While examples of successful collaboration are multiplying, it can be a battle to make it work. There is a tendency to compete rather than collaborate, and difficult issues to resolve in each case such as transferability and copyright. Technology, too, remains a major issue: making it work, access, integration. Despite the advances made by new technologies, print retains its lead in distance education, and is likely to remain the most important medium well into the next century.

Distance education also has far to go in achieving the social objectives which were central to the thinking of many of its founders. A recent study of distance education throughout Europe has found that there is greater and more varied provision of distance education in those countries which have the most highly developed conventional education systems. Of the twelve countries in the European Union, Holland and the UK have the most distance education, while Greece, one of the poorer countries, has very little. It is little used where needed more. Paradoxically, it is the best method for reaching those at the margins of society, but in practice better at reaching those who have most. In particular, there is the challenge of lower level non-formal education. Such education tends to have a low profile, and it is possible that experience is under reported, but probable that there is little action and much remains to be done. AIOU is exceptional as a university in the amount of attention it gives to all educational levels. Other open universities may offer a wide range of courses, but the amount of activity at each level elsewhere does not appear to be proportional in relation to need.

Distance education has a certain future, but what does that future hold? It is possible that further growth will be accompanied by less visibility. As it takes the lead in changing higher education and training it is likely to become less differentiated from conventional options, and gradually integrated into the mainstream.

PAKISTAN JOURNAL OF DISTANCE EDUCATION

Volume — X

1993

Issue — I & II



Allama Iqbal Open University
Islamabad — Pakistan

**A MULTI-MEDIA APPROACH TO EFFECTIVE TEACHING
AN EVALUATION REPORT ON THE GCE(OL) INTEGRATED
COURSE AT THE ACCRA WORKERS' COLLEGE**

by

DR. ERIC A. MENSAH*

INTRODUCTION

The Background

This evaluation report is concerned with the General Certificate of Education Ordinary Level (GCE OL) Course organized by the Accra Workers' College. The college serves as the downtown centre of the Institute of Adult Education, University of Ghana in the City of Accra as well as the Regional Office for university-based adult education programmes in the Greater Accra Region. Apart from the GCE Course which is organized at both Ordinary and Advanced Levels, the College's programmes include Degree Courses of the University of Ghana, Professional Courses mainly in Accounting and Banking, Access Courses for prospective "Mature" Students of the University of Ghana, and Training Courses for Supervisors, Superintendents and Senior Management personnel in industry and voluntary organizations.

The Accra Workers' College started the organization of what is now known as the GCE (OL) Integrated Course. The programme is so called because it combines two main teaching methods, namely, study by distance education course notes and face to face meetings. Great emphasis is also placed on written assignments. The course notes are supposed to be so comprehensive students are expected to rely upon them almost entirely for their studies. The College nevertheless encourages students to read from other sources.

*The writer is working as Resident Tutor. Institute of Adult Education, University of Ghana.

The rationale behind the introduction of this course was rooted in two main areas of concern. First, there was a need to find a more effective and efficient teaching method for the GCE course which started to dominate the Institute's programmes when Workers' Colleges were established throughout the country in 1962. Secondly, the course was designed to enhance the Institute's pioneering and leadership roles in the field by a search for new instructional methods and techniques that would facilitate the learning process by maximizing the use of available resources.

The Workers' Colleges of the Institute of Adult Education appeared to be ill-prepared for the GCE course when it was introduced in 1962. Such unpreparedness led

to a heavy reliance on part-time tutors who specialized in secondary school education but who were not integrated into the course and curriculum policy of the Institute (Neilson et al, 1970).

The introduction of the new course symbolized a marked departure from previous course offerings. The British adult education tradition of liberal studies was, until 1962, the dominant feature of the Institute's programmes. But to most of the programme's participants these courses augmented their private preparations for public examinations of one kind or another. It would therefore appear that the new courses which were introduced in response to a Presidential fiat merely confirmed a trend which had been building up over the years. This seems to explain the enthusiasm with which the new courses were supported by previous programme participants and a new breed of students mainly young adults.

The new courses were also supported for vocational reasons. Most of the students registered to enable them claim an increase in salary. For example, teachers who passed a certain number of GCE subjects were given incremental credits and this proved a strong motivating factor. Another dimension of the vocational factor

concerned those workers having very poor qualifications and a feeling that their chances of promotion in their jobs were threatened. For this category of workers too, the GCE course offered greater job security.

Many students also registered to improve upon grades obtained at previous examinations. In short, the new course provided opportunities for individuals who had to interrupt their formal education for one reason or another to continue with their further education.

Apart from the unpreparedness of the Institute's staff for the new programme, some other factors appeared to have conspired to prevent successful programming. For example, an examinable course such as the GCE had precise needs for textbooks without which it could not be pursued satisfactorily. The books were, however, either not available or very expensive to be obtained. Moreover, in the nature of evening classes for workers there is a limit to the number of hours face to face meetings could be organized in particular subjects. It, therefore, became necessary to find some other means of maximizing student-tutor contact at class meetings.

A Multi-media approach

The GCE (OL) Integrated Course was introduced to accommodate some of the problems posed for the Institute of Adult Education by the challenges experienced with the organization of the course in the conventional mode.

The new course is based upon one of the variations of the group study method using distance education methods, namely, the Directed Group Study. Group study was built into the programme to benefit from the unique advantages of group learning such as discussion, and motivation from pressures, interests and activities of others. The entire course is under the direction of an instructor who meets the group at stipulated times. All members of the group participate and prepare individual assignments since the course is examinable and

qualificatory.

The advantages of this teaching method are the same as those associated with distance education generally. The programme is individualized by the interaction between tutor and student through written assignments and subsequent face to face meetings. The programme could, therefore, be adjusted to suit levels of ability and difference backgrounds. Students are able to study at any time and even at any place. And in the Ghanaian context, the self-contained and comprehensive reading material provided is able to accommodate the non-availability of books and prohibitive prices. No other educational procedure has yet been devised with such flexibility and versatility.

The purpose and design of the evaluation

Two main groups were used for the evaluation. The experimental group was made up of 159 students enrolled in the First Year GCE (OL) Integrated Course at the Accra Workers' College. The treatment comprised study through self-contained distance education course notes supplied by the Institute of Adult Education, face to face teaching and an emphasis on written assignments and self-tests for each lesson. This group was scheduled to write the GCE (OL) Final Examination in June, 1983.

The control group also comprised 81 students enrolled in the First Year GCE(OL) course at the Sekondi-Takoradi Workers' College. The treatment consisted of study by face to face teaching with occasional written work. The group was regarded as a non-equivalent (non-randomized) control group because the characteristics of its members were similar to that of the experimental group at the Accra Workers' College. This group was also scheduled to write the GCE(OL) Final examination in 1984.

The evaluation design was as follows:

X_E O_1 O_2 O_3 O_4

X_c O₁ O₂ O₃ O₄

Where X is treatment

E experimental group

C control group

O observations of tests made at the end of each academic year with effect from the 1980/81 academic session

1-3 series of tests made for years 1, 2 and 3, namely, 1980/81, 1981/82 and 1982/83.

4 final observation, test or GCE Examination in June 1983 and 1984 respectively.

The lack of resources made it impossible to carry out the observations or tests in 1981-82 and 1982-83.

Course Profile

Members of both the experimental and control groups were offered tuition in English Language, Modern Mathematics, Economics and Principles of Accounts. The course format for the control group was fashioned on the conventional mode.

The combination of distance course notes and face to face meetings for the experimental group, however, needed a different format. Course notes for each subject were distributed to students on particular days. Students were required to read the notes and then answer the questions in a Self-Test at the end of each lesson. The exercise was designed to test the student's understanding of the material presented. Each lesson also had a written assignment which students were expected to attempt and return to the College for marking and grading. Again, the questions in the written assignments were designed to give the student a further opportunity to find out how much he had learnt, and to practise the presentation of clear and logical answers. Each course comprised a number of lessons as follows:

<u>Subject</u>	<u>No. of Lessons</u>
English Language.....	40
Modern Mathematics.....	40
Economics.....	20
Principles of Accounts.....	20

Each lesson in the course was in turn handled in a six-stage cycle of events, such as:

- 1) Collection of lesson by student
- 2) Introduction of lesson at a face to face meeting
- 3) Return of written assignment by student
- 4) Collection of written assignment by tutor
- 5) Return of written assignment submitted by students
- 6) Review of marked written assignment at a face to face meeting.

After the second face to face meeting, the cycle was re-activated for the next lesson until the course was completed. A calendar was supplied to indicate the course of events for each subject.

The following Tables I and II provide some general information about the members of both experimental and control groups. Course participants were mainly male with both groups registering over 90% in this category in each case. The drop-out rate was also much higher with the control group. And these factors affected the number of students presented at the GCE (OL) Examination by Accra in 1983 and by Sekondi-Takoradi in 1984.

Table-I**COURSE PROFILE OF EXPERIMENTAL GROUP**

	Male (N=14)		Female (N=15)	
	<u>No.</u>	<u>%</u>	<u>No.</u>	<u>%</u>
No. Enrolled for Course (159)	144	90.57	15	9.55
No. Registered for Examination	37	25.70	2	13.33
No. Participated in Final Examination	33	22.92	2	13.33
No. Dropped Out	107	74.30	13	86.67

Table-II**COURSE PROFILE OF CONTROL GROUP**

	Male (N=74)		Female (N=4)	
	<u>No.</u>	<u>%</u>	<u>No.</u>	<u>%</u>
No. Enrolled for Course (81)	74	91.36	7	8.64
No. Registered for Examination	6	8.11	1	4.29
No. Participated in Final Examination	5	6.76	1	14.29
No. Dropped Out	68	91.0	6	85.71

INTERIM EVALUATION - 1981

At the end of the 1980-81 academic session, the programme was evaluated to determine whether or not it was on course. The study embraced student effectiveness, an end of year examination and attitudes of course participants to programme implementation. These variables are now discussed as follows.

Effective Students

Two main variables were used to determine student's effectiveness, namely, attendance at face to face meetings and written work. The Institute's traditional standard of effectiveness (the accomplishment of two-thirds of any learning activity) was used. Table III provides an analysis of the performance of both experimental and control groups on the two variables.

There was some disparity between the number of written assignments and face to face meetings organized for the two groups. On the one hand, the Accra group wrote ten assignments in each subject as against four in English Language by the Sekondi-Takoradi group. There was also some evidence of written work by the control group in Modern Mathematics, but the details of this activity were not available. On the other hand, the Accra group attended only 10 face to face meetings in English and Modern Mathematics as against 30 meetings organized for the group at Sekondi-Takoradi.

Table-III

ANALYSIS OF FACE TO FACE MEETINGS AND WRITTEN ASSIGNMENTS ORGANIZED FOR EXPERIMENTAL AND CONTROL GROUPS

Subjects	Meet-	Effec-	Non-	Meet-	Effec-	Non-		
	ings/ Assi- gnmen- ts	tive Stu- dents	Effec- tive Stu- dents	ings/ Assi- gnmen- ts	tive Stu- dents	Effec- tive Stu- dents	No.	%

Meetings

Eng.Lan- guage	10	61	38.36	98	64.00	30	45	55.56	36	44.44
Modern Maths.	10	70	44.03	89	55.97	30	24	60.00	16	40.00

Assignments

Eng.Lan- guage	10	118	74.21	41	25.79	4	56	69.14	25	30.86
Modern Maths.	10	107	67.30	52	32.70	*	*	*	*	*

*Details of number of written assignments undertaken not available.

It would appear from Table-III that written assignments were more popular than face to face meetings in both groups. The percentages of effective students recorded for this activity in English Language and Modern Mathematics were 74.21% and 67.30% respectively in Accra, and 69.14% for English Language at Sekondi-Takoradi. These percentages were higher than those recorded for face to face meetings organized in the two

subjects, namely, 38.36% and 44.03% in Accra and 55.56% and 60.00% at Sekondi-Takoradi respectively.

End of Year Examination

The experimental and control groups were matched against each other in an end of year examination conducted in English Language and Modern Mathematics. The English Language paper was in three parts. The first part was made up of letter writing, and students were asked to read two passages and answer objective questions in the second part. The third part also comprised miscellaneous exercises on punctuation, arrangement of words in alphabetical order, correction of sentences and some other exercises. On the other hand, the Modern Mathematics paper covered the following topics: the number system, the metric system, number bases, modular arithmetic, sets, subsets, and the number of elements in a set.

The examination was organized for both groups at their respective centres on the same day. Four secondary school teachers in Modern Mathematics and English Language confirmed on request that the examination papers covered topics normally taught to first year students in the formal school system.

The grades attained by both the experimental and control groups were arranged according to percentile ranks to determine (1) whether or not there was any statistical relationship between the treatment received by either group and the results of the examination; and (2) whether or not either of the two groups attained statistically significant higher ranks than the other.

Table-IV

**Distribution of Experimental And Control Groups
According to Percentile Ranks Attained in English Language**

Group	Percentile Ranks (1)			
	N	Above P75	Between P75-P25	Below P25
Accra (Experimental Group)	123	34	62	27
Sekondi-Takoradi (Control Group)	53	10	25	18

$\chi^2 = 3.34, p < .05$
 $\frac{2}{(1)}$ Mann Whitney-U, $p > .05$

Table IV shows that the obtained chi-square of 3.34 was not statistically significant for the English Language paper. On the other hand, a Mann whitney-U test indicated that one set of ranks was significantly higher than the other. This appears to indicate that although there was no statistical relationship between the type of programme used by members of either group and their performance, the Accra group attained statistically higher ranks than the Sekondi Takoradi group.

TABLE V

DISTRIBUTION OF EXPERIMENTAL AND CONTROL GROUPS ACCORDING
TO PERCENTILE RANKS ATTAINED IN MODERN MATHEMATICS

Percentile Ranks (1)

Group	N	Above P75	Between P75-P25	Below P25
Accra (Experimental Group)	108	35	56	17
Sekondi- Takoradi (Control Group)	47	-	26	21

$$\chi^2 = 34.84, p > .01$$

$$^{(1)}\text{Mann Whitney-U, } p > .01$$

Table V shows a marked difference between the distribution of the percentile ranks for both the experimental and control groups in the Modern Mathematics paper. The obtained chi-square of 34.84 and the Mann Whitney-U test on ranking were both statistically significant. This also appears to indicate that in addition to the statistical relationship established between the type of programme used for the teaching of Modern Mathematics, the Accra group attained statistically higher ranks than the Sekondi-Takoradi group.

Written Assignments

The volume and grade-point-average of written assignments were analysed to determine whether or not there was any relationship between either or both variable with performance at the examination. The relationship

that existed between these variables, however, appeared to be qualitative rather than quantitative. It was also not linear and could not therefore be tested for statistical significance.

TABLE VI

DISTRIBUTION OF EXPERIMENTAL GROUP ACCORDING
TO NUMBER OF WRITTEN ASSIGNMENTS SUBMITTED
AND PERCENTILE RANKS ATTAINED IN ENGLISH
LANGUAGE AND MODERN MATHEMATICS

Subject/Percentile Rank	No.	Percent	High (7-10)	Medium (4-6)	Low (0-3)
<u>English Language</u> (N=159)					
Above P75	34	21.39	29	4	1
Between P75-P25	62	38.99	52	9	1
Below P25	27	16.98	20	5	2
Examination Dropouts	36	22.64	2	6	28
	159	100.00	103 (64.78)	24 (15.09)	32 (20.13)
<u>Modern Mathematics</u> (N=159)					
Above P75	37	23.27	33	3	1
Between P75-P25	54	33.96	42	12	-
Below P25	17	10.69	8	5	4
Examination Dropouts	51	32.08	7	13	31
	159	100.00	90 (56.60)	33 (20.75)	36 (22.65)

Table VI shows the distribution of written assignments submitted by the experimental group for both English Language and Modern Mathematics. Two-thirds of

the number of written assignments offered was rated 'high' according to the Institute's criterion for effectiveness; the next two thirds were then classified as 'medium' and 'low' respectively. Apart from the examination dropouts in both cases, the pattern for the submission and volume of written assignments appeared to have no relationship with performance at the examination.

A comparative analysis of percentile ranks and grade-point-average attained in written assignments, however, seemed to indicate some relationship between performance and end of year examination. It would appear from Table VIII, therefore, that those students whose grade point averages were in the higher ranges also performed better at the examination. This relationship was however not great enough to be tested for statistical significance.

TABLE VII

COMPARATIVE ANALYSIS OF PERCENTILE RANKS AT
END OF YEAR EXAMINATION AND GRADE POINT
AVERAGE ATTAINED IN WRITTEN ASSIGNMENTS

	Above P75 (N=34)		Between P75-P25 (N=62)		Below P25 (N=27)	
Subject/Grade	No.	Percent	No.	Percent	No.	Percent
<u>English</u>						
<u>Language</u>						
A+	-	-	-	-	-	-
A	11	32.35	3	4.84	-	-
B+	15	44.12	22	35.49	1	3.70
B	4	11.77	25	40.32	3	11.11
C+	3	8.82	8	12.90	14	51.86
C	-	-	3	4.84	7	25.93
D	1	2.94	1	1.61	1	3.70
E	-	-	-	-	-	-
Nil Returns	-	-	-	-	1	3.70
	34	100.00	62	100.00	27	100.00

Modern Mathematics

A+	5	13.51	2	3.70	-	-
A	9	24.32	13	24.08	2	11.76
B+	14	37.85	15	27.78	2	11.76
B	7	18.92	15	27.78	6	35.30
C+	1	2.70	7	12.96	4	23.54
C	-	-	2	3.70	2	11.76
D	-	-	-	-	-	-
E	1	2.70	-	-	1	5.88
	37	100.00	54	100.00	17	100.00

Face to Face Meeting

The attendance at face to face meetings was analysed to determine which of the two groups attended more meetings. It is important to note, however, that members of the experimental group attended 10 meetings as against 30 by the control group. The variability in attendance within each group, therefore, needs to be considered against this background.

Tables VIII and IX show the distribution of the experimental and control groups respectively according to percentile ranks and attendance at face to face meetings. The Institute's standard of effectiveness was again used to divide the number of meetings attended into thirds of 'high' 'medium' and 'low' respectively. On the basis of this classification, more effective students attended face to face meetings in Modern Mathematics than in English Language among members of the experimental group. The examination dropouts in both cases also appeared to be of those students who attended relatively fewer face to face meetings.

Table VIII

Distribution of Experimental Group According
to Percentile Ranks at end of Year
Examination and Attendance at Face to
Face Meetings

Subject/Percentile Rank	No.	Percent	High (7-10)	Medium (4-6)	Low (0-3)
<u>English Language</u>					
(N=159)					
Above P75	34	21.39	20	11	3
Between P75-P25	62	38.99	27	24	11
Below P25	27	16.98	11	8	8
Examination Dropouts	36	22.64	2	4	30
	159	100.00	60 (37.74)	47 (29.56)	52 (32.70)
<u>Modern Mathematics</u>					
(N=159)					
Above P75	37	23.27	32	4	1
Between P75-P25	54	33.96	32	14	8
Below P25	17	10.69	6	4	7
Examination Dropouts	51	32.08	1	13	37
	159	100.00	71 (44.66)	35 (22.01)	53 (33.33)

The incomplete data on the second Modern Mathematics class at Sekondi-Takoradi did not facilitate much comparison. The two Tables,

Table IX

Distribution of Control Group According
to Percentile Ranks at end of Year
Examination and Attendance
At Face to Face Meetings

Subject/Percentile Rank	No.	Percent	High (20-30)	Medium (11-19)	Low (0-10)
<u>English Language</u> (N=72)					
Above P75	10	13.89	6	4	-
Between P75-P25	25	34.72	17	8	-
Below P25	18	25.00	15	2	1
Examination Dropouts	19	26.39	4	11	4
	72	100.00	42 (58.34)	25 (34.72)	5 (6.94)
<u>Modern Mathematics</u> (N=75)					
Above P75	-	-	-	-	-
Between P75-P25	26	34.67	6	*	*
Below P25	21	28.00	5	*	*
Examination Dropouts	28	37.33	13	8	7
	75	100.00	24	8	7

*Class register for Modern Mathematics class was not available, hence incomplete record.

nevertheless, provide some additional characteristics about the dropouts in both groups. The percentages of students in this category were higher in both subjects within the control group (26.39%) and 37.33%) than within the experimental group (22.64%) and 32.08%) in English Language and Modern Mathematics respectively.

Attitudes to Programme Implementation

Two questionnaires were administered to members of both experimental and control groups to ascertain their attitudes to the implementation of the GCE (OL) programme at each centre. A consumer measurement scale developed by Bitter and Goodyear was used to analyse responses to the questionnaires. (Bitter and Goodyear, 1974). Students were asked to express either satisfaction or dissatisfaction about certain aspects of the organisation of the two programmes evaluated. They were asked to check the appropriate points on a Likert-type scale according to their attitudes.

A response was scored -2 if it was extremely negative, -1 for the next point on the negative scale, and 0 for a neutral answer. A +1 and +2 conversely indicated satisfaction progressively on the positive side of the scale. The levels of satisfaction were registered as 'high', 'medium' or 'low' depending upon the degree of satisfaction indicated by each person. The low levels of satisfaction ranged from 0 to +.70; medium levels from +.71 to +1.40 and high levels from +.41 to +2.00. The continuum of satisfaction/dissatisfaction was thus portrayed as follows:

<u>Dissatisfaction</u>				<u>Satisfaction</u>		
-2	-1.40	-.70	0	+.70	+1.40	+2.00
High	Medium	Low		Low	Medium	High

The mean of the total score for each question was fitted into the continuum to determine the degree of satisfaction or dissatisfaction score for any particular question. The scores for all the questions were also combined to yield a mean score indicating the degree of overall satisfaction or dissatisfaction with the implementation of the GCE(OL) programme at each centre.

Table X shows that the experimental group was more satisfied than the control group with the programme. The mean score of 1.29 for the Accra group fitted into the

'medium' range of the satisfaction end of the continuum whereas that for the Sekondi-Takoradi group fell within the 'low' range of the same end of the continuum.

Table-X

A Comparative Analysis of Attitudes of Experimental and Control Groups Towards Programme Implementation
Mean Scores of Satisfaction Scales

	Experimental Group (Accra:N=86)	Control Group Sekondi-Takoradi:N=41)
<u>Written Work</u>		
Utility of Written Assignments	1.76	1.39
Utility of practice exercises	1.71	-
Satisfaction with marking of written assignments	1.23	0.98
<u>Face to Face Meetings</u>		
Generally added to understanding of course	1.41	-
Adequately dealt with questions on written assignments	1.06	-
Class discussions and understanding of English Language Course	-	1.27
Class Discussion and understanding of Modern Mathematics course	-	-0.73
<u>English Language Course</u>		
How course was generally taught	1.50	1.20
Effectiveness of class	-	0.90

sessions and difficulties encountered in studies

Enjoyment of reading supplements to English Language course 1.78 -

Modern Mathematics course

How course was generally taught 1.14 -0.04

Effectiveness of Class sessions and difficulties encountered - -0.73

Part-time Tutors

General approach to teaching 1.07 0.78

End of Year Examination

Extent to which regarded preparation adequate 1.02 0.15

Time Table

Adequacy of period taken to complete first year's course in English Language 1.28 0.95

Adequacy of period taken to complete first year's course in Modern Mathematics 0.95 0.12

Satisfaction with time table 0.81 0.39

Course Notes

Adequacy of notes 1.26

Overall Satisfaction/Dissatisfaction Mean Score:

Accra	<u>1.29</u>
Sekondi-Takoradi	<u>0.63</u>

Questions related to the Modern Mathematics course received low scores (-0.04 and -0.73) with the Sekondi-Takoradi group especially. The scores for whether or not the period taken to complete the first year's course in Modern Mathematics was adequate, were also lower within both the experimental and control groups than the scores for similar questions on English Language.

On the other hand, the English Language course received relatively favourable scores within both groups. The scores for the questions on how the subject was generally taught were 'high' (1.50) for Accra and 'medium' (1.30) for Sekondi-Takoradi respectively. English Language also scored 1.28 for the adequacy of the period taken to complete the first year's course within the Accra group, and 0.95 within the Sekondi-Takoradi group.

Students in both experimental and control groups did not appear satisfied with the manner in which their time tables were structured. Satisfaction with the timetable received the lowest score (0.81) with the Accra group while the Sekondi-Takoradi group scored the question 0.39. Students in both groups were also apparently not satisfied with the extent to which they were prepared for the end of year examination. The Sekondi-Takoradi group's score for the question was as low as 0.15 and Accra's score of 1.02 fitted into the 'medium' range of the satisfaction end of the continuum.

Written assignments were scored fairly high. The utility of written assignments per se and practice exercises were scored 'high' (1.76 and 1.71) by the experimental group who were also fairly satisfied with the manner in which the assignments were marked (1.23). The control group were equally fairly satisfied with a score of 1.39 just under the 'high' point at the satisfaction end of the continuum.

An open-ended question included in the questionnaire administered invited suggestions or criticisms for the improvement of the teaching and organization of the GCE(OL) course at both centres. Many of the respondents took advantage of this invitation to either emphasize or elaborate upon previous responses. Tables XI and XII show the analyses of these observations.

Table XI

**Analysis of Observations Made by Experimental Group
Respondents (N=86)**

<u>Nature of Observation</u>	<u>No. of Respondents</u>
1) Re-organize General Science Course	17
2) Organize more face to face meetings	17
3) Organize face to face meetings immediately after submission of written assignments	9
4) Give more time to Modern Mathematics	9
5) Some part-time tutors cannot express themselves well enough to make us understand them	7
6) Let Part-time tutors teach and explain rather than answer questions from written assignments only	7
7) Part-time tutors need to be punctual	6
8) General Science (Biology) meeting hours were inconvenient	5
9) Some tutors did a good job. Let them stay with us until the end of our course	5
10) Pace of course is too slow	4
11) Some tutors were impatient and unfriendly	3
12) Transportation was a problem	2

The frequencies of categories of observations, made by students, appear in both Tables XI and XII in a descending order of importance with regard to the

attitudes of students to programme implementation. The dominant issues among members of the experimental group appeared to be the General Science course, the restructuring of face to face meetings, the Modern Mathematics course, and part-time tutors. On the other hand, the control group seemed to be much concerned with the teaching of the Modern Mathematics course, scarcity of books, the general performance of part-time tutors and a need for a scheme of work to facilitate their studies.

Table XII

**Analysis of Observations Made By Control
Group Respondents (N=41)**

<u>Nature of Observations</u>	<u>No. of Respondents</u>
1) The Modern Mathematics course was not properly organized	18
2) Scarcity of books was a major problem	14
3) The English Language tutor did a good job	11
4) Some of the part-time tutors lacked teaching skills and experience	11
5) Provide students with a scheme of work for them to know ground to be covered within any specified period	8
6) Part-time tutors need to be punctual	6
7) Relieve Modern Mathematics tutor of his post	6
8) Increase number of periods allocated for each subject	3
9) Part-time tutors must exercise patience with students	3
10) Transportation was a problem; organize transport for us	3
11) The English Language course was	2

- not properly organized
- 12) The Modern Mathematics tutor was all right. 2

The General Science course which was made up of face to face meetings only for the experimental group was much criticized. Suggestions for improvement included the following: (1) A change in the hours for face to face meetings which were sometimes held between 4-5 p.m. (2) The supply of reading material (3) A new approach by part-time tutors to facilitate understanding. The Accra group also asked for more face to face meetings as well as a restructuring of the timetable such that written assignments would be discussed soon after submission.

Some respondents from Accra observed bluntly that they needed more time for Modern Mathematics because they found the subject difficult. On the other hand, the teaching and organization of the Modern Mathematics course was the major concern of the Sekondi-Takoradi group. Some of the members of this group stated that the course was not properly organized and their disappointment with part-time tutors was mainly centred upon their tutors in that subject. As indicated in Table XII, some of them demanded that their tutor be relieved of his appointment. Criticism of the performance of part-time tutors included lack of teaching experience, failure to be punctual, unfriendliness and impatience with students. Members of both groups appeared to be very critical of their tutors. There were, however, some positive remarks as well on the work of part-time tutors. Some members of the experimental group were so pleased with their tutors that they wished to remain in their classes until the end of the course. It will also be observed from Table XI that as many as 11 members of the control group specifically indicated their appreciation of how their English Language tutor taught the subject.

Final Examination Results

The Grading System

The GCE (OL) Integrated Course was designed as a three year course as against the course at Sekondi-Takoradi which was organized for four years. Students were offered English Language and Modern Mathematics in the first year. And in the second year, Economics and Principles of Accounts were added. The General Science course was also available if the student so desired to add it to the four subjects. The pioneers of the course in the experimental group were therefore registered for the West African Examination Council's GCE(OL) Examination in May/June, 1983 while their counterparts in the control group were registered for the 1984 examination in May/June, 1984.

Attainment in a subject at the Examination is indicated by the grade. Grade 1 is the highest and Grade 9, the lowest. Grades 1,2 and 3 are Excellent, Very Good and Good respectively. Grades 3,4,5 and 6 are categorized as Credits. Grade 6 is, in fact, the minimum standard needed to satisfy university entrance requirements. Grades 7 and 8 are passes, and Grade 9 is Fail. Tables XIII and XIV indicate the examination results of both experimental and control groups.

Table XIII

WAEC May/June 1983 GCE(OL) Examination Results
For Experimental Group Showing Grade Range

Grade Range	English Language		Modern Mathematics		Economics		Accounts	
	No.	%	No.	%	No.	%	No.	%
1-6	10	29	2	6	4	12	7	24
7-8	9	26	7	21	8	24	6	21
9	16	45	25	73	22	64	16	55
	35	100	34	100	34	100	29	100

Table XIV

WAEC May/June 1984 GCE(OL) Examination
Results for Control Group Showing Grade Range

Grade Range	English Language		Modern Mathematics		Economics		Accounts	
	No.	%	No.	%	No.	%	No.	%
1-6	1	17	1	17	-	-	-	-
7-8	3	50	1	17	1	17	1	17
9	2	33	4	66	5	83	3	75
	6	100	6	100	6	100	4	100

Credit Achievement Rates

A higher percentage of credits in the 1-6 grade range was recorded by the experimental group, namely, 29% against 17% for the control group. Again, the Accra group recorded passes in this grade range for Economics and Principles of Accounts while Sekondi-Takoradi had no passes in this category. Modern Mathematics appeared to be a problem subject in both groups. The percentages of failures were 73% and 66% for both experimental and control groups respectively. And the failure rate for Economics and Principles of Accounts was much higher with the control group.

Table XV

**Credit Achievement Rate in
Experimental and Control Groups**

No. of Credits obtained	Accra (N=37)		Sekondi- Takoradi (N=7)	
	No.	%	No.	%
4	1	2.70	-	-
3	1	2.70	-	-
2	3	8.11	-	-
1	10	27.03	2	28.57

Either a pass or a credit at the GCE Examination, especially in English Language, greatly enhances a worker's chance for promotion. It appears, therefore, that at least some 19 members of the experimental group as against 4 members of the control group were enabled to benefit in this direction.

Implications, Conclusions and Recommendations

It would appear from both the interim evaluation and the final examination results that the credibility of the GCE(OL) Integrated course has been firmly established.

The statistically higher percentile ranks attained by the Accra group in both English Language and Modern Mathematics at the end of year examination in 1981 seems to be reflected in the Final Year Examination results in both 1983 and 1984 (See Tables XIII, XIV and XV). It may, therefore, be concluded that the treatment given to the experimental group was more qualitative than that received by the control group.

The qualitative superiority of the GCE(OL) Integrated

Course also appeared to have manifested itself very early in the programme. For example, at the interim evaluation of the programme, some kind of relationship was established between grade point average and achievement at the end of year examination rather than with either the number of written assignments undertaken and face to face meetings attended. And this early realization of the programme's quality was reflected in the credit achievement rate in the experimental group (See Table XV).

It would appear that compared with the conventional programme at Sekondi-Takoradi, the GCE(OL) Integrated Course was able to accommodate problems such as lack of books and schemes of work which appeared to be major constraints for members of the control group. It might even be conjectured that members of the experimental group compared the teaching methods of the new programme with that for the General Science course which was taught in the conventional mode, hence their very critical observations about that course.

It seems, nevertheless, important to be cautious about the implications of the foregoing observations for a variety of reasons. First, it appears from the observations made by members of the control group at the interim evaluation that the English Language programme had a formidable competitor in the person of the part-time Tutor at Sekondi-Takoradi. On the one hand, the remarkable statistical relationship between the performance of the Accra group and the programme in Modern Mathematics also had in the background a part-time Tutor who appeared from all indications to have performed below expectation at Sekondi-Takoradi. Given the validity of these observations, it would seem that the part-time Tutor is a very important variable in these programmes. Moreover, on the basis of the Institute's traditional measure of effectiveness, the control group had more effective students than the experimental group in both written assignments and face to face meetings during the first year's evaluation. It is also important, however, to read this observation against the disparity in the numbers of both learning activities for the two groups.

The critical remarks by members of both groups about part-time Tutors also seem to indicate a serious shortcoming in class organization. Part-time staff development in the Institute continues to comprise sporadic arrangements. And the time seems to have come for a well structured training programme which would be organized as part of the normal business of the Institute. The face needs to be recognized, however, that there is a limit to what part-time Tutors may contribute to teaching programmes since a vast majority of them will continue to be non-professionals. It seems reasonable, therefore, to provide them with the necessary framework within which they could operate effectively. For example, the General Science course which received much criticism has been restructured with a detailed scheme of work, reading material and lesson plans. It is hoped that this would provide a basis for effective teaching expected of tutors who may not otherwise be in a position to organize their teaching in this fashion for one reason or another. The lapses identified in the foregoing may have contributed to the perception of inadequate preparation especially among members of the control group as compared with the experimental group.

The criticism of the Accra group concerning the schedule for face to face meetings which were not well synchronized with written assignments was found to be valid. New lessons were sometimes discussed when written assignments for previous lessons had not yet completed the cycle to be in readiness for discussion. Moreover, the programmed nature of the GCE(OL) Integrated course appears to favour the student who is able to keep pace with the system. It, therefore, seemed to operate to the disadvantage of the slow learner or student who was below average. In these circumstances, it was found necessary to restructure the timetable to provide for more face to face meetings. Each lesson therefore now has two face to face meetings: the first meeting is used to introduce the lesson, and the second meeting is used to discuss the lesson's written assignment. A lesson is, therefore, completely disposed of after two face to face meetings.

Two main schools of thought appear to characterize

the various studies which have been conducted into how to maximize tutor-learner interaction in learning situations. The first may be identified with what is the best method or technique for instruction. And the second, the conditions and situations under which available methods or techniques are most effective.

As articulated by Palmer and Verner, a majority of these studies have identified the lecture method as equal or better than other methods or techniques in terms of immediate recall. And, this is the main activity associated with the conventional mode of teaching at face to face meetings. It has also been observed, however, that in most adult education activities immediate recall is less important than sustained learning. The lecture method is therefore less desirable in such programmes. It is nevertheless conceded that where the programme is examinable and qualificatory, it would seem more desirable to use the lecture because of its superiority in immediate recall (Palmer and Verner, 1965).

The second school of thought whose adherents may be described as situational or contingency theorists, however, advocates that the superiority of one method or technique is more a factor of the relationship of the learner to the technique rather than a factor inherent in the technique itself. And this relationship would, therefore, be particularly identified in terms of the individual's situation (Hall and Cushing, 1947). In fact, it has been argued by Spence that the question of comparative efficiency among techniques is of less importance than determining situations under which a particular technique or method is more efficient (Spence, 1928).

The observations made about the part-time Tutors in English Language and Modern Mathematics at Sekondi-Takoradi and Accra respectively, for example, seem to lend some credibility to the foregoing argument. Moreover, given the validity of these conclusions, it would appear that there is a need for the Institute of Adult Education to organize systematic programmes for part-time Tutors in place of the current sporadic arrangements for this

type of activity. As a previous survey has indicated, very few part-time Tutors attend these courses in any case because they want to discuss and exchange ideas rather than be lectured on how to teach and the theories of psychology (Neilson et al, 1970).

These observations, notwithstanding, the constraints that characterize part-time studies in developing countries such as Ghana appear to call for teaching methods or techniques which are qualitative to maximize tutor-student interaction. And the attitudes of both the experimental and control groups to programme implementation seem to support this assertion in their own particular ways.

The issues that dominated the observations of the control group appeared to have been accommodated by the treatment given to the experimental group. For example, scarcity of books was not mentioned by the Accra group because of the comprehensiveness of their course notes. The Sekondi-Takoradi group also called for schemes of work which appeared to suggest in ill-structured programme. Again, the nature of the programme in Accra was such that students were fully aware of the scheme of things. As observed earlier however, the adverse comments by the Accra group about the General Science course appeared to indicate a comparison with the treatment they received under the GCE (OL) Integrated course. The concern about the limited time at the disposal of both groups also appears to demonstrate a need for qualitative rather than quantitative treatment.

It would appear from the findings of the evaluation that although the results of the experimental group were not spectacular, the GCE(OL) Integrated Course is a qualitatively superior teaching method and therefore needs to be adopted for the Institute's centres throughout the country.

The qualitative superiority of the GCE(OL) Integrated Course was demonstrated in the statistically higher percentile ranks attained by the Accra group in both English Language and Modern Mathematics at the end of

year examination in 1981. And this superiority was also reflected in the Final Year Examination results in both 1983 and 1984. In fact, as indicated during the interim evaluation, some kind of relationship was established between grade point average and achievement among the experimental group rather than with either the number of written assignments undertaken and face to face meetings attended.

The failure to establish a relationship with either of these variables appeared to indicate that the course notes constituted an important variable which was not covered by the evaluation. The degree of comprehensiveness and a content analysis of the course notes vis a vis the GCE(OL) syllabus are therefore, recommended for further study.

This evaluation did not also cover relationships that might have existed between the apparent high drop-out rates in both experimental and control groups, and the nature of the treatment given to members of both groups. The phenomenon is therefore, worthy of further study.

The higher drop-out rate identified with the control group nevertheless appears to suggest that the new course was able to mitigate the unusually high drop-out rate that seems to characterize such adult education activities. It would appear that this finding also further strengthens the credibility of the GCE(OL) Integrated Course.

PAKISTAN JOURNAL OF DISTANCE EDUCATION

Volume — X

1993

Issue — I & II



Allama Iqbal Open University
Islamabad — Pakistan

WINDOW ON DISTANCE LEARNING INSTITUTIONS

(A Case Study of al-Quds Open University)

The Role and Tasks of Tutors In Distance Education System of Al-Quds Open University

By

Dr. Taiseer Zaid Kailani*

I Introduction

Al-Quds Open University (QOU) is an innovative higher institution in the Arab World, adopting a model of distance education based on the principles of self-directed learning, learner's autonomy and tutorial provision. This mode of education is enhanced by employing an appropriate mix of educational media such as: printed materials, video cassettes, audio-cassettes, computers, study packages, TV and radio programmes and other modern technical means in the fields of communication and information. (QOU Prospectus, 1993)

Al-Quds Open University was established in 1986 with the intention of providing opportunities in higher education and training for the maximum number of Palestinian, Jordanian and Arab men and women. The headquarters are located in Amman, Jordan, a base from which the University can serve wider Arab needs for higher education. As a start, QOU has established a network of 18 regional and local study centres in the West Bank of the River Jordan and in the Gaza Strip (now under Israeli occupation). QOU employs 160 academic tutors to facilitate students' study. (Ayush, 1993, p.15)

*The writer is working as Director General of the Academic Department, Al-Quds Open University, Amman, Jordan. In this paper he describes with some detail the tutors' role in relation to the educational model adopted by al-Quds Open University.

In combination with core curricula courses, referred to as foundation courses, QOU offers programmes in five educational fields leading to B.A/B.Sc. degrees. These are: Technology and Applied Sciences; Social and Family Development; Management and Entrepreneurship; Agriculture and General Education. (QOU Prospectus, 1993, p.8) These programmes have been designed to satisfy the actual needs of Palestinian and other Arab applicants. In addition, the University offers programme of continuing education and training where a learner may select specific courses to meet his/her individual needs and receive a certified credit on successful completion. Thus, the University contributes to the general development of Arab communities.

II. The Learning-Teaching System

The approach of learning-teaching adopted by QOU is based mainly on two components, namely: self-study distance method and tutorial services. The printed material, in such model of distance education, constitutes the main medium of instruction. This is essential to its effectiveness because the written text presents the students with source material, replaces the lecture and encourages the student to think in an independent manner by means of well-designed questions and learning tasks within the text. (Perry and Rumble, 1987, p.9) Furthermore, printed course material can be an active medium through which a form of two-way communication can be established between the tutor and the student. Accordingly, students are provided with well-structured distance education materials and assigned to tutors whom they meet, now and then, for educational purposes at the local centres in or near their home towns or villages.

III. The Purpose of the Study

The purpose of this paper is twofold. The first is to offer an analytic description of the tutorial provision provided at al-Quds Open University, and the second is to define the role of the tutor to the open learning student with the hope to familiarize the Arab

learner with the effectiveness and necessity of the tutoring system in distance education. A successful distance education system needs, along with good instructional material, a solid background of academic support services in order to ensure success for its students.

Being the first open university in the Arab World, the challenge facing QOU is, therefore, how to make the people appreciate its innovative system of distance education in which tutoring and counselling play a vital role. This tutorial provision, in fact, is what distinguishes QOU from other correspondence universities like Beirut Arab University in Lebanon which employs open learning without providing any support service to its external students. (Beirut Arab University Catalogue, 1990, p.12-16)

V. Methodology

Data collected, for this study, come mainly from four resources, namely, (1) statistical data of QOU Review, (2) substantial literature that already exists on the topic, (3) the author's observation and experience in distance education, and (4) a short form of Tutor Questionnaire which includes 16 open questions designed to get relevant information about the tutoring system currently used at the University. These difference means would make the study more valid and the results more reliable.

VI. Analysis

1. Qualifications, Experience and Mode of Work:

One of the most difficult tasks confronting a new open university is the recruitment of qualified academic staff. The selection of a competent tutor plays an important role in the success of the system. Accordingly, the tutor needs appropriate academic and professional qualifications in order that he can perform his role effectively and confidently.

At al-Quds Open University an attempt was made, from the beginning of the academic programmes in 1988, to obtain tutors with some experience in teaching adults as well as in distance education, but the University has faced, since then, a shortage of trained tutors. Generally, most of the tutors were employed on part-time contracts with no pre-service training in tutorial service. (Othman et al, 1993, p.12) This condition of employing inexperienced tutors was possibly dictated by the rapid expansion of study centres across the country and by the financial problems which made it difficult to recruit tutors qualified as such and of real interest in this education. This opinion of the tutors is confirmed by the statistical abstracts of the University which denote that tutors do not receive adequate orientation in course material, didactics, the University's policies and procedures before joining the tutoring service. (QOU Review, 1992, pp. 17-19)

However, the University can make up for this shortcoming by conducting a training course for candidates selected as tutors where they can be introduced to the distance education system and gain appropriate coaching qualifications, good inter-personal skills and experience in adult education. It goes without saying furthermore that tutors need academic and moral support as well as practice in a repertoire of communication skills so that they can function adequately and establish sound inter-personal relationships with the students at the outset.

2. Work Load and Types of Contact

At al-QOU tutors are employed on a semester-by-semester basis and most of them are part-time tutors. Out of the 160 academic tutors employed by QOU, only 24 work on full-time contracts. (QOU Review, 1993, p.20) They are hired from regional universities and each one of them has responsibility for more than 30 students whom they meet in smaller groups of 10-15 students every two weeks at the rate of one hour per session. In these sessions they discuss with the students subject-

matter, marking and evaluation, problems with teaching materials or with assignments, students' personal problems regarding tutorial meetings and other relevant issues or information.

Students' attendance, at the local centres, is compulsory. Students are encouraged to meet with their tutors to make further progress in their studies. In fact, face-to-face interaction is the only form of contact available at QOU. Other forms of contact such as telephone calls, teletutorials, writing letters and self-help groups are not used. Probably this is because most of the study centres are newly established and not well-equipped with means and ways of telecommunication to help tutors contact their students who, in most cases, have no access to channels of communication to and from the study centres.

Since attendance at the study centre is a requirement on the part of students, according to the mode of distance education adopted by QOU, all tutor/student consultations and tutorial services are noted in several forms of records. Thus tutors keep accurate and adequate records of students' performance, of marks and comments and of completed assignments. These records are considered as an integral part of the tutorial provision. They help the tutor, who acts as the liaison between the university and the students, to track the progress of the students during the course and to report to the university administration on their achievement in the given course. This process of record keeping by the tutor adds a new dimension of strength to the distance education system as it stimulates students to follow up their studies and to meet with tutors regularly as scheduled, a state of affairs which enhances academic support services and the role of the tutor in maintaining a unique standard of university education.

3. The Concept of Distance Education

Tutors were requested to define the meaning of distance education within the perspective of the ap-

proach adopted by QOU. The results were not expected as hoped and in some cases inaccurate. This is probably because tutors, whether they are full-time or part-time, were appointed without any training in open learning systems. It is necessary that they know the philosophy and principles of distance education where they are functioning; otherwise they may not perform their role adequately.

The term distance education is usually defined as teaching, guiding and helping the student at a distance supported by tutors, stored information and by using multi-media and correspondence techniques. (Allana, 1985, pp. 1-2)

This definition implies that there is both distance teaching and distance learning as well as some form of two way communication between teacher and learner accompanied by pre-prepared learning materials suitable for distance education. Communication, in distance education, happens with the help of any medium that is available such as: the written word, telephone, fax, telex, postal or electronic mail, cassettes or tapes, face-to-face meetings, and modems allowing the linkage of computers and TV screen by telephone.

There are many other related terms that are used for this approach such as: external study, independent study, correspondence study, off-campus study, home study, open learning, non-traditional study, and the like. None of these, however, can describe specifically the meaning of distance education because they are common terms, referring generally to this kind of education but they do not include the elements of distance education as defined by, for example, Keegan (1985, p.33) which goes as follows:

- The separation of teacher and learner which distinguishes it from face-to face lecturing.
- The influence of an educational organization which distinguishes

it from private study.

- The use of technical media, usually print, to unite teacher and learner and carry the educational content.
- The provision of two-way communication so that the student may benefit from or even initiate dialogue.
- The possibility of occasional/regular meetings for both didactic and socialisation purposes.

However, in this study, we occasionally use the term "open learning/education" as a synonym for distance education though it is a generic term to which a range of meanings can be attached.

4. The Tutor and the Study Centre

Al-Quds Open University provides space for laboratory exercises, workshops, tutorial classes, library resources and examinations. These academic activities are practised at local centres conveniently located for the students in order to ameliorate as many of the disadvantages of self-learning as possible. Eighteen study centres have been established in the West Bank and the Gaza Strip. Each of them has its own director who is responsible for providing relevant services to ensure effective student support. According to the academic support system adopted by QOU, the role of these centres is:

- To provide academic counselling, orientation meetings, and personal advice.
- To make books and teaching materials available for study and research.

- To provide access to educational facilities.
- To provide a place for course examinations to be held.
- To provide a place for students to meet with the tutor to discuss matters concerning their study, or to learn from each other in discussion groups.
- To provide a place for students to view or to listen to relevant teaching/learning materials broadcast on television or radio.

The tutors assigned to the student support system seem to be aware of the rationale and function of the study centre as concluded by their answers to the question which asks if the study centre is anything more than a place where personal interaction is offered by a tutor. Thus, they have viewed the study centre as (a) the focal point where the tutors provide supervision, advice and counselling on study matters and course materials, (b) the place where learners have access to educational facilities, and (c) an optimal learning situation where educational support services are provided. This conclusion has its favourable effect on the student support services in general and on tutorial provision in particular.

However, there is some dissatisfaction with the working conditions at the study centres as concluded from the tutors' answers to the question which investigates the problems they encounter in their work. The following shortcomings are reported:

- Teaching and learning facilities are not sufficient as in the case of laboratories and libraries.
- There is a shortage in printers,

copiers, TV sets and computers.

- Facilities of telecommunication to and from the study centres are not satisfactory.
- There are no sufficient halls or classes to accommodate the tutorial sessions that might concurrently be given.
- Recreation facilities, e.g. cafeterias, are not satisfactory.

These drawbacks are strongly supported by a recent report, submitted to the UNESCO, on the problems confronting open learning program in the West Bank and Gaza Strip (Kamal, 1993, pp.8-10), a condition which requires an immediate remedy so that the centres can function as adequately as planned by the University.

5. The Tutor/Student Relationship

Personal contacts (tutor-student and student-student) are a necessity which must be developed in any successful distance education system. What the open learning student needs is someone who assesses and comments on assignments, who explores and examines, and who discusses strategies for understanding the learning material. In this manner, the open learner can break down the isolation of individual/home study and develop effective dialogue which is the basis of education, and eventually achieve the broader educational aim of personal development. (Clennel, et al, 1977, p.22) A good tutor can, indeed, make all the difference to the learner's study even if the learning material is perfect. That is why the main strength of an open university lies in its tutorial staff who, in addition to the academic services they provide, act as the bridge between the students and institution.

It is important to keep in mind that the majority of distance education students are adults with a great variety of educational background or experience. Besides, they have limited time for studying since they are likely to be engaged in other full-time activities. Such learners, without doubt, need, among other things, academic and support services in order to progress in their study and continue with it. This attitude is confirmed by our tutors in their answers to the item which inquires about the learners' real needs in distance teaching system. In our context, these services are offered only through tutors in some 18 local study centres across the country, a state of affair which consolidates the role of the tutor as the element which provides stability and continuity in the life of the Open University student and ensures success for him. For these reasons the tutor-student relationship, in terms of face-to-face meetings or tutorial sessions, should be considered as an essential component of the system of distance education as a whole.

6. The Tutor's Educational Functions

Al-Quds Open University is a student centred institution where much emphasis is laid on academic support services provided at a network of study centres located throughout the country. With regard to this mode of distance education, the students are attached to specialist tutors who deal with them as individuals in terms of the academic content of the teaching materials, and mark and comment on their assignments in a process of continuous assessment. So together with the use of attractive self-instructional materials, the University has endeavoured, from the beginning of its Open Learning Programme, to provide a high quality of education just as good as that in reputable conventional universities. Tutors, in such educational system, have a great responsibility for the success of the University because they are required to elucidate the subject-matter of the relevant courses and to help students both academically and personally. This result is concluded from the answers of the question which investigates the educational functions that might be

performed by the tutor.

The following functions are reported:

- Arousing attention and motivation.
- Referring to objectives.
- Referring to the teaching material.
- Correcting, giving explanation and guidance.
- Activating the learners.
- Marking assignments and tests, commenting on them and providing feedback.
- Pacing schedules, updating of the subject-matter.
- Discussing course content, and facilitating retention of material.
- Organizing laboratory sessions, seminars, or discussions and self-help groups.

The question that may be raised in this connection is "How can tutors facilitate the students' learning and ensure their success in the study?" With regard to this issue, Race has remarked that tutors can help open university learners by:

- making them feel at ease;
- building up their confidence;
- helping them feel they are not alone;

- convincing them that their worries are common ones;
- telling them you are there to help, not just to assess;
- reassuring them that most people make the same mistakes they make;
- helping them embark on their studies in an organized and productive way;
- reminding them that even that the hardest things can be mastered one step at a time;
- giving practical advice regarding revision strategies and exam techniques;
- reminding them that there present studies can lead them to choices and opportunities, in the future, and
- by posing a warm, friendly attitude and opening up channels of communication with them. (Race, 1989, p.110)

In addition to these sorts of educational help, there is the problem of drop-out from the open learning program and how can the tutor counteract it. As we have indicated before, most distance education students are adults of different educational, social and motivational backgrounds as well as with different personal and study problems, a condition which results in the face that many of them cease to study on an open-learning program prior to its completion.

It is noticed that the drop-out rate is considerable in mid-course as students are likely to give

up study because the work is getting harder, the material tougher and the marks lower, or because they have failed to gain some special knowledge. (QOU Review, 1993, p.12) In fact, there's a host of causes for non-completion such as: lack of time, changed plans, travel distance, ill health, shortage of time, family duties, financial difficulties, employment pressures, unclear goals, ineffective coaching or guidance, bad teaching, difficult or uninspiring course material, too long assignments, a harsh or inadequate tutor, getting fed up or frightened of forthcoming exams. (Rekkedal, 1987, p.24)

Whatever the reasons of non-completion, the tutor must address them fully and try to take the best possible care of the students right from the outset of their study; otherwise there may soon be no students to take care of! Most tutors, however, seem to be aware of these causes and know how to tackle them as concluded from their answers to the question which investigates the means and ways in which the tutor can counteract drop-out from the course. The following techniques were reported in this connection:

- By providing help when the students meet difficulties in their studies.
- By being good at explaining faults.
- By taking a personal interest in the students and their study progress.
- By adopting an adequate behaviour towards the students.

- By telling them that the university interested in their progress and their study problems.

- By taking the best possible care of the students in the beginning of the course.
- By trying to follow up the students' work.
- By writing to passive students or telephoning them.
- By promoting students' motivation through encouraging and establishing personal contact.

Further to these remedies, tutor qualities such as competency, warmth, enthusiasm and empathy can indeed strengthen the students' motivation and enhance their perseverance to complete their open learning programme.

7. Characteristics of a Good Tutor

We have seen that the tutor, in a distance education system, is a subject-matter expert who normally provides academic support services like teaching, guiding, discussing strategies for understanding the material, evaluating students', achievement, correcting students' assignments and commenting or giving feedback on students' progress.

In the light of these and other similar functions the tutor should have, in the first place, qualifications like those of the teaching staff in any university and relationship skills in order to be able (a) to meet the learning needs which are specific to the students and (b) to establish sound interpersonal relationships with students. The list of desirable tutor qualities is long and varied; but here are the most important characteristics reported by the tutors in their answers to the question which investigates qualities of a competent tutor. Thus they have stated that a good tutor should have:

- good knowledge of the subject-

matter and teaching expertise;

- some knowledge of distance education systems;
- warmth, enthusiasm and empathy;
- acquaintance with distance learning techniques;
- good knowledge of evaluation techniques;
- a constant source of inspiration;
- up-to-date knowledge of all the learning materials available;
- an ability to imagine what the students need;
- awareness of the students' difficulties;
- a skill in communication;
- an interest in the students and their study progress;
- an ability to explain faults, and
- readiness at providing help.

In brief, an efficient tutor should have, among other things, a wise background, in theory and practice, of tutoring work, a repertoire of human relationships and some communication skills in order to make tutoring truly effective and to provide stability and continuity in the life of the Open University student.

8. Issues Encountering Tutoring

Thus far, it has been evident that there are some

problems associated with tutorial provision in distance education. This is also concluded from the answers to the query which aims to find out the problems that might be encountered by the tutors in their work. The following are the major problems as stated by the tutors in some way or the other:

- 1) As the tutor provides the vital breath to the system, stability and continuity in life of the distance student and credibility to an educational programme, it is necessary that this aspect of the Open University is adequately taken care of.
- 2) Since the tutors have heavy teaching loads, the question that rises from this situation is whether they are effective in providing tutorial services or in solving the students' problems.
- 3) Non-delivery of course material on time often disturbs the schedule of the would-be taken courses, confuses the students when selecting the courses available and eventually handicaps the tutor as he cannot discuss the course content with the students in the absence of the print material.
- 4) The function or the role of the tutor is not properly defined to students whether he is just a facilitator or a teacher as well. Students must be told right from the beginning what they should expect from their academic tutor and what duties are required of him in the tutoring process.

- 5) Short falls in the preparation of the course material are often a source of complaint among tutors and students as well. It is sometimes the case that the self-instructional material or the exercises or assignments associated with it are either of mediocre quality or above the standard of the students. This weakness is probably due to the lack of rigour at the time of the preparation of the course material or because the author of the material has not assimilated the subject he is writing in, which results in the material turning out to be unreadable or too difficult to understand.

- 6) Evening tutorial sessions are inconvenient to female students or learners in part-time employment who would prefer morning tutorials because mothers of children prefer to attend tutorials while their children are at school, and students in part-time employment may have time during the day to attend tutorials. The problem of this situation is that the majority of the academic staff are part-time tutors who cannot provide tutorials in the morning. However, the problem can be solved by appointing full time tutors who can hold sessions of times convenient to different categories of students.

The rate of drop-out is high which causes some disappointment itself reflected in the effectiveness (or otherwise) of the tutorial sessions and the activities associa-

and detailed knowledge of the course content, distance education expertise and a repertoire of communication skills so that the pure stream of knowledge will reach the students undaunted and their per-severance in the study can be secured. However, to maintain the tutors morale he must feel that he is not neglected and that he is supported financially and morally by the University so that he can perform his role effectively and confidently to the advantage of the distance education student.

PAKISTAN JOURNAL OF DISTANCE EDUCATION

Volume — X

1993

Issue — I & II



Allama Iqbal Open University
Islamabad — Pakistan

Tutor Questionnaire

Dear Tutor

You are kindly requested to give your opinion about the following queries to the best of your knowledge. Your ideas and suggestions will help me to find out how academic tutors in distance education function and what their responsibilities are. Your answers will provide me with useful information in my study which aims at improving the role of the tutor in distance education. Please do not write more than five lines in your answer to each query.

Thank you for your cooperation.

- 1 Have you received any pre-service training in tutoring distance education students?
- 2 What does distance education mean to you?
- 3 How do you understand the tutoring process?
- 4 Do you think that open university students need tutoring?
- 5 How many students do you have responsibility for?
- 6 What form of records do you keep?
- 7 How do you perceive your role as a tutor?
- 8 What special traits should a tutor have?
- 9 What educational functions can a tutor provide?
- 10 How can a tutor help open university students?
- 11 What is your view of the Study Centre?
- 12 Are you satisfied with the working conditions at the study centre you belong to?
- 13 Why do some students drop their courses?
- 14 How can a tutor counteract course-dropping?
- 15 What problems do you encounter in your work as a tutor?
- 16 Have you any views on the tutoring system that you would like to express?

References

- Allana, Ali, "Higher education at a distance", Indian Journal of Distance Education, Vol.2, Chandigarh, India, 1987.
- Amer, Yunis, "Educational facilities in the open learning programme", QOU Review, Amman, Jordan, 1993.
- Ayush, Theyab, "Characteristics of the academic staff at QOU"., QOU Review, Amman, Jordan, 1993.
- Beirut Arab University Catalogue, Beirut, Lebanon, 1990.
- Clennel, S., and Sewart, D., Teaching For the Open University, Bucks, England, Walton Hall Publisher, 1977.
- Delling, R.M., "Support systems in distance education", Open Campus, Vol.3, Australia, Deaken University Press, 1982.
- Kamal, Sufyan, "The Problems Confronting the Open Learning Programme in the Occupied Territories of Palestine", QOU Review, Amman, Jordan, 1993.
- Keegan, Desmond, "On defining distance education", Distance Education, Vol.1, No.1, Australia: Croom Helm Ltd., 1986.
- Koul, B.N., and Jenkins, J., Distance Education, A Spectrum of Case Studies, London, England: Kegan Page publisher, 1990.
- Mugridge, I., and Kaufam, D., Distance Education in Canada, Kent, England: Croom Helm Ltd., 1986.
- Othman, D., and Shahan, M., "Evaluation of distance education, a case study of QOU", QOU Review, Amman, Jordan, 1993.

- Paine, N., Open Learning in Transition, Cambridge, England, National Extension College, Trust Ltd., 1988.
- Perry, W., and Rumble, G., A Short Guide to Distance Education, Cambridge, England, International Extension College, Publisher, 1988.
- QOU, Prospectus, Amman, Jordan, 1993.
- QOU Review, Amman, Jordan, 1992.
- Race, Phil., The Open Learning Handbook, London, England: Kogan Page Publisher, 1989.
- Rekkedal, Torstein and Baath, John, Course For Tutors, AECS., Sweden, DIOL Ltd., 1987.
- The American Journals of Distance Education, Pennsylvania State University, U.S.A.
- Epistolo Didaktika, The European Journal of Distance Education (AECS) U.K.
- Indian Journal of Distance Education, Punjab University Press, Chandigarh, India.
- International Council For Distance Education, (icde), Bulletin, Toronto, Canada.
- Journal of Distance Education, The Canadian Association for Distance Education, Ontario, Canada.
- Open Campus, Deakin University, Victoria, Australia.
- Open Learning, Longman, England.
- Pakistan Journal of Distance Education, Allama Iqbal Open University, Islamabad, Pakistan.

SPECIAL FEATURES

BOOK REVIEW

Foundations of Distance Education

By

Desmond Keegan*

Desmond Keegan is not unknown to the persons pertaining to distance education system. He has a number of feathers in his cap due to his varied and versatile services in the field. He has the credit to be the first Director General of the Distance University in Italy. He founded the international journal Distance Education which has promoted the cause of distance education system all over the world. Being a Chairman of research committee of the International Council for Distance Education, Mr. Desmond has done a lot to locate the indepth problems confronting to the system of non-formal education. Thus, he appears to be an authority on the topic and a milestone in the way of eliminating illiteracy from the global village.

For this auspicious mission, Desmond Keegan has not merely remained confined to the campus and even the corridors of the committee, rather he has gone ahead in writing an authentic book Foundations of Distance Education so as to explore smooth and benefitting way to the goal. In the late eighties, the first edition of the said book came out with thunder-bolt. It was such a popular, thought provoking and think-tank type of treatise that all the printed copies were sold out within a short span of three years. It came as a

*Routledge, 11 New Fetter Lane, London, EC 4P 4EE & 29 West 35th Street, New York, NY 10001.
1990 (Second Ed.), PP-214, Price not mentioned.

pleasant surprise to the learned author, who on the request of Routledge, prepared a second edition of the book in question making full use of recently published work. Thus, the author has made the second print more praiseworthy, prudent and pruned.

There is no denying the fact that distance education is a growing international phenomenon. At a time when the new and advanced technology is absolutely changing the nature and norm of much higher education, and new social and economic demands are being made of traditional education, distance education is emerging as a component of higher and adult education in many countries. In this perspective, Desmond's book under review appears to be a survey of thinking, writing and practice in the field and specifically drawing attention to the new and impressive systems being developed in Asian Countries. It is undoubtedly an authoritative study and offers a sound basis for further research in several areas relating to distance education. The students as well as the researchers will surely and candidly get valuable insights into this form of education either belonging to countries with advanced technologies or adhering to others with less developed economics, of course, the book presents varied dimension and thus proves to be of great value.

Dr Mahmudur Rahman

Editor/PJDE

Director Official Language Project, AIU.

BOOK REVIEW

PROMINENT PERSONALITIES OF THE MUSLIM WORLD

By

Dr Mahmudur Rahman

Published by National Book Foundation,
Govt. of Pakistan, Islamabad.

Pages: 330
Size : 23 x 36/16
Price: Rs.135/=

Year of Publication: 1993

There is no denying the fact that life sketches of distinguished devotees and prominent personalities appear to be a lighthouse for the nation which intends to capture the canvas horizon of capabilities and to attain the height of horizontal dignity. The works and achievements of luminaries undoubtedly make a history. Their lofty ideals and continued struggles for the noble cause kindle the lamp of lucubration in the hearts of new generation and even provide them lubrication for attaining a gigantic goal in the sphere of life. Thus, these dignified figures of history become a fruitful and benefitting source of inspiration for the young men of our society.

It is gratifying to note that Dr Mahmudur Rahman, a writer of repute, has come up with a valuable venture to vindicate and visualise the glorious achievements of more than seventy renowned Muslim Poets, philosophers, scholastics, educationists and reformers of the South Asian countries. All such luminaries, specially that of the subcontinent, have rendered great services to the cause of education in this region.

In the book under review, we find a number of such persons who had devoted their lives to elminate the spots of illiteracy from their society. Mention may be made of Sir Syed Ahmad Khan, Sir Aga Khan, Nawab Mohsin-ul-Mulk, Nawab Waqar-ul-Mulk and Maulana

Mohammad Ali who spread the rays of learning through the establishment of Aligarh Muslim University and Jamia Milli, Delhi in undivided India. The learned author has also described the lofty deeds of Sir Ziauddin, Allama I.A. Kazi, Sir Ross Masud, Dr Ishtiaq Hussain Qureshi and Prof M.M. Ahmad who had worked as Vice-Chancellors of Muslim University of Aligarh, India, Sindh University, Hyderabad and the University of Karachi (Pakistan).

The noted educationist and ex-Vice-Chancellor of Allama Iqbal Open University, Islamabad has rightly said in his foreword to this book:

"This book is undoubtedly a guide for those young and inexperienced persons who are about to enter the wide sea of life. They can read in it the brief biographies of great men of our Islamic culture, which in turn, will prompt them to strive for success, to fight for truth and to endeavour for the achievement of their cherished goal".

As a reviewer, I feel confident that the students of our colleges and universities will inevitably be able to derive real inspiration and lofty lessons from the lives and achievements of prominent personalities portrayed by our senior colleague, Dr Mahmudur Rahman.

Masooda Chaudhry
Associate Editor

PAKISTAN JOURNAL OF DISTANCE EDUCATION

Volume — X

1993

Issue — I & II



Allama Iqbal Open University
Islamabad — Pakistan

NEWS AND VIEWS

BY

IQBAL HUSSAIN

There has been a lot of activities on the AIOU's campuses during the calander year of 1993. A new academic block besides the three faculty buildings have been constructed and brought into use while construction work on two more has been commenced.

The university attracted the dignitaries of international repute, scholars and experts both within Pakistan and from overseas. A number of staff members attended international conferences and seminars. Many of them were nominated and had training abroad. A brief account of the activities might more clear a picture what happend during the period.

UK REVIEW MISSION BRIEFED AT AIOU

A high-level review mission of UK Overseas Development Administration (ODA) visited Allama Iqbal Open University in February, 1993. The mission consisted of Dr. David Pemycuik, Senior Education Advisor, Dr. Aancoles, Adviser on Social Development, Mr. Harri hagan, Development Economists, and Mr. Michael Hughes of the West Asia Department. The team had a preliminary briefing session with Vice-Chancellor Dr. S.A Siddiqui and Senior Staff members.

The purpose of their week long visit was both general as well as specific. The University has been receiving ODA support since 1979. The mission was to evaluate the effectiveness of these inputs in relation to the agreed objectives.

The mission reviewed the on-campus development by visiting and had meetings with concerned Officers/Heads of departments and also visited the Regional Campus, Lahore and to a field centre for Basic Arabic functional literacy.

DR. RAO APPRISED THE ACTIVITIES OF COL

Professor Dr. Chandrasekhars Rao, Director Asian programme and Training, Commonwealth of Learning (COL), Canada, was on two days visit of the Allama Iqbal Open University in March, 1993.

Professor Rao, who was Vice-Chancellor Andhra Pradesh Open University before taking charge of his present assignment, had discussions with Vice-Chancellor, the three Deans, Heads of Administrative and Servicing Departments and faculty members.

He had the opportunity of not only apprising them of the activities of the Commonwealth of Learning, but also of knowing the views and proposals of the AIOU's faculty vis-a-vis commonwealth of learning's own programmes which will serve as necessary feed-back to plan and organised COL's Asian programmes.

The guest briefed the Vice-Chancellor and the Deans about the decisions of the recently held conference of the Vice-Chancellors of open universities in Sri Lanka and requested for AIOU's action cooperation in implementing these.

Professor Rao also had a meeting with Federal Minister of Education, Syed Fakhar Imam and apprised him of COL's activities with particular reference to its programmes related to AIOU. He had a similar meeting with chairman UGC.

NORAD OFFICIAL HIGHLIGHTS ROLE OF EDUCATION

To improve education is to improve the development process of nation and the quality of life of the population, observed Ragnvald Dehl, resident representative of NORAD. He was speaking as a chief guest at the opening of the PTOC Senior Tutors workshop held at Allama Iqbal Open University. (April 1993)

Ragnvald Dehl said that a good and well qualified teacher is the most valuable asset in the education

system of a nation. He emphasised the need for providing purposeful education and necessary training to the female population of Pakistan.

At the occasion, A.D. Khan, Deputy Education Advisor, Ministry of Education, said that this project under which some 42000 primary school teachers will be provided in-service training, is of vital importance for our education.

Addressing the meeting the Vice-Chancellor Dr. S.A. Siddiqui informed the participants that PTOC (Primary Teachers Orientation Course) project is among the pioneer programmes of the university. He added that the New PTOC is an improved version of the old programme with many new features such as regular monitoring, supervision, management, added emphasis on practical training and incentives for teachers etc. Dr. Siddiqui told that some 4500 students have been enrolled for the session starting from May, 1993.

DR. LETON THOMAS VISIT TO AIOU

Dr. Leton Thomas, a prominent educationist of West Indies and Principal of Sir Arthus Lewis, College, St Lucia visited here in July, 1993, under the Commonwealth of Learning, Canada.

He met with Vice-Chancellor of AIOU. The main purpose of Dr. Thomas's visit was: To assess the Commonwealth of Learning's performance and achievements since its establishment to consider the balances and emphasis in COL's strategic plan and the programmes and activities through which they were being realised in various parts of the commonwealth, to review the development and management of the organization and consider the appropriateness of its present structure as an institution promoting education at a distance, to examine the implications of COL's modes of financing, to recommend any changes to the memorandum of understanding, to report to commonwealth governments with recommendations for COL's further development.

During the days in Pakistan he also visited local historical and other places.

AIOU is one of the Best Institution of Distance Education in World

"The AIOU is perhaps the first institution taking the most modern audio-visual equipment to the country side", observed Dr. M.H. Kazi, member University Grants Commission (UGC), while delivering micro-teaching equipment to 12 Regional Campuses/Offices of the University, the equipment, which includes audio-visual camras with inbuilt VCRs, TV sets, Tripods together with all necessary accessories, has been donated by NORAD (Norwegian Agency for development) for the use of the New PTOC project. Dr. M.H. Kazi maintained that AIOU, which is among the best institutions of distance education in the world, has a great potential to meet the challenges of the modern world.

Syrian Minister Appreciated AIOU's Education Plan

The Syrian Minister for higher education, Dr. Salihasangar visited AIOU in September, 1993, said that "She is impressed with the technical education programme being undertaken by the Allama Iqbal Open University".

The Syrian Minister paid a visit to the Radio and T.V studios of the university and showed keen interest in the education programmes, remarked "This is an age of progress of Technical and communication sources and it is also the basic purpose of life to accomplish these achievements.

She said "I fully appreciate the efforts of the university to train the people in appropriate ways". She offered good wishes for the progress of the institution.

Five Members Yamani Team Visited AIOU

A high level Yamani educational delegation under the leadership of Mohammad Abdullah Shami visited the Allama Iqbal Open University in October, 1993. The leader of the delegation observed that "at present the Yamani educational institutions are over crowded for which they find no solution insight".

Welcoming the guest on behalf of the university Prof. Javed Iqbal Syed said that the AIOU being a first and successful experience proved attraction as a model for countries like India, Sri Lanka, Thailand and Bangladesh. The University had solved to a great extent, the problem of over crowded of formal institutions of Pakistan. Prof. Javed offered them as "We would be happy to extend every possible help to brotherly Yamani people in the field of distance education".

Other Considerable Visits to University

- A three members team of Bangladesh consisting of Prof. Mafizuddin, Director (Admn), BOU, Mr. Shahjuddin, Deputy Secretary, Ministry of Education and Syed Zial-Haque, Asstt. Director (R,S&E), BOU visited here in April, 1993 to review administration, financial management, media production, development and distribution and functions of Regional Offices of AIOU.
- Mr. Qasim Ahmed, Associate Professor and Director off Campus Activities, University of Sains Malaysia to review the "Distance Education, programme of AIOU", in May 1993.
- Mrs. S.A Hakim, Programme Co-ordinator UNESCO, Kabal, with their

16 members team of English teachers visited on 12th September to University Campus. They were briefed about the current development and methods of "Teaching of English as Foreign Language (TEFL), M.A Level programme of the University.

UK/ODA Consultancies

Apart from the long-term Great-Britian Consultancies of Mr. Alec Fleming since 1983 and F.L Cook from 1984, UK/ODA also providing short term consultancies in various fields of interest of the university.

The following consultants completed short-term assignments during 1993.

<u>Sr. No.</u>	<u>Name of Consultant</u>	<u>Area/Subject</u>	<u>Dates of Visit</u>
1.	Ms. M. Lancaster	Computing	19th January
2.	Dr. D. Smith	Computing	29th January
3.	Mr. M. Iles	Project Control	-do-
4.	Mrs. J. Field	Project Control	-do-
5.	Mr. A. Beattle	Community Health	5th February
6.	Mr. W. Watson	Print Production	27th March
7.	Prof. J. Hough	University Planning Management	13th April
8.	Miss J. Lease	IET Engineering	11th May
9.	Dr. D. Warr	BUESP Review	14th May
10.	Mr. B. Reeves	BUESP Review	14th May
11.	Mrs. B. Robinson	Staff Development	14th May
12.	Mr. M. Davidge	Financial Management	20th April
13.	Mr. R. Hall	Activity Costing	20th April

WORKSHOPS/SEMINARS

Workshop for M.Phil Islamic Studies

The Department of Arabic and Islamic Studies arranged a weeklong workshop for M.Phil Islamic Studies students started from 10th July, 1993 at the main campus of the University.

AIOU M.Ed Programme

Second national level 10 (Ten) days workshop for M.Ed programme of teachers of the visually impaired children was conducted from September 20 to 29, by the department of Special Education of the Allama Iqbal Open University.

Dr. M. Tariq Siddiqui assumes charge as New Vice-Chancellor

Dr. M. Tariq Siddiqui, former Civil Servent, brings with him a wide ranging experiences as an administrator and an educationist, assumed the charge of the office of the Vice-Chancellor of the Allama Iqbal Open University on 3rd April 1993. His appointment was done by the then president of Pakistan who was also the Chancellor of AIOU.

Govt. Scheme to provide Training through AIOU

The Federal cabinet has approved a scheme to provide training to 10,000 educated youth annually as teachers through AIOU for generating self employment in the country. As a concomitant, the scheme will help in improving the quality of education in line with government policy which accords top priority to the education sector.

AIOU to start MSc Women Studies

The first course of its kind in the country at the Master level on the "Psychology of Women" had been written in Allama Iqbal Open University.

This was stated by Dr. I.N. Hassan while addressing the first course team meeting held here in June 1993. She also pointed out that "three more courses be completed by Spring 1994" to be followed by enrolment for Masters in "Women Studies". This is an AIOU Project funded by Minsitry for Women's Development.

Women's Matric Programme

After the successful experiment of Secondary School Certificate (SSC) Project for seven years, from Spring, 1994 semester, the Matriculation level education will be offered through-out Pakistan as a regular programme of AIOU. The programme is being opened now for females from both Urban and Rural areas. For rural females there is special fee concession.

Certificates for 1083 students completed Elementary Literacy Course

On 29th December, the AIOU Bureau of University Extention and Special Projects gave away certificates to 1083 male and female students of Bhara Kahu Union Council, District Islamabad who have completed their elementary Literacy course. Initially 4823 students were enrolled out of which 2473 female and 395 male students have completed their course. UNICEF has funded all the female centres while the study centres for male students were funded by NETCOM.

Speaking on the occasion Prof. Mrs. Razia Abbas, Director, BUESP told that she was really inspired to see the enthusiasm of the females of the area in transforming their lot through education. Prof. Dr. S.A. Siddiqui, who presided over the ceremony, congratulated the students over their success and remarked that they should regard this success as their starting point. Mrs. Yasmin Ahsan of UNICEF, Pakistan, who was the Chief Guest, remarked that education was like light which must be disseminated over the entire society. Mr. Muhammad Din, the Project Director, thanked the students, Teachers and the guests.

**PTV2, STN Telecast AIOU
Admission Programme**

All centres of PTV2 and STN telecast a comprehensive introductory admission programme of the Allama Iqbal Open University for Autumn 1993, semester on 2nd and 5th June and for Spring 1994, semester on 27th and 30th November respectively.

"PYAMI" is a Global Level Publication

"Payami" an urdu edition of "courier" and being published by Allama Iqbal Open University, Islamabad. This urdu edition is presented in highly sophisticated style of printing. The standard of publication is so much attractive that at Paris Headquarters it has been frankly admitted: "among 36 global editions of courier, there appear only three which published in most decent way. Urdu edition stand third in rank".

Through the publication of "Pyami", the AIOU is playing a gigantic role in promoting education and culture and enriching the national language of Pakistan the translation of thought-provoking articles written by world fame scholars appear to be treasure for the general readers, and students alike.

It is hoped, this urdu edition of UNESCO Courier", Paris will get a good response from all concerned quarters.

About 44 years ago UNESCO started publishing a monthly magazine "UNESCO Courier" in English, French and Spanish languages from headquarters, Paris.

It also arranged to bring out Courier's editions in 36 noted languages of the world, such as Russian, Chinese, Greek, German, Italian, Arabic, Persian, Tarkish, Hindi, Bangali, and "Urdu", the national language of Pakistan.

Staff Development

A) Scholarships for higher studies:-

- Mrs. Farrukh Tahir, Lecturer to proceed for Ph.D studies in London on 29th June, 1993 under commonwealth general scheme for 1993-94.
- After his selection, Mr. Tanveeruz-Zaman, Lecturer also to pursue the same higher studies (Ph.D) of commonwealth scholarship tatable in U.K w.e.f 30th September, 1993.

B) Training, Seminars/Meetings abroad

<u>Sr. No.</u>	<u>Name and Designation</u>	<u>Subject</u>	<u>Country</u> <u>Duration</u>
1.	Mr. Arshad Hafeez Printer, Print Production Unit.	To attend the course of Printing in Napier Univer- sity, Edinburgh	U.K. three, months w.e.f. 15/1/93
2.	Mrs. Nuzhat Haider Asstt. Professor Deptt. of Women Education	To persue higher studies under Netherland Fellowship Programme	Netherland, Six Months w.e.f. 6/01/93
3.	Mr. Hafeez Ullah Registrar	UK. Training under ODA Phase-IV Programme	U.K., Six weeks w.e.f. 12/02/93
4.	Mr. Muhammad Khurshid Controller of Exams.	-do-	-do-

- | | | | |
|-----|---|---|---------------------------------------|
| 5. | Mr. Muhammad Rafique
Planning Officer | -do- | -do- |
| 6. | Mr. Nisar A. Aziz, Lecturer | -do- | -do- |
| 7. | Mr. Javed Iqbal Syed, Professor | To attend an International Conference of V.Cs of Open Universities | Sri Lanka three days, w.e.f. 09/03/93 |
| 8. | Mrs. Shahnaz Asjad, Lecturer IAIS | Training ODA Phase-IV Programme | U.K. Four Months w.e.f. 12/03/93 |
| 9. | Mrs. Shaista Babar Lecturer, Deptt. of Home Economics | -do- | -do- |
| 10. | Ms. Faiza Tabassum Lecturer | -do- | -do- |
| 11. | Dr. Daud Awan Deptt. of Math. Stat. & Computer Sciences | Orientation meeting for the cal/ National tutors and National Coordinators at the NYSC, Colombo, Sri Lanka. | Sri Lanka Three days w.e.f. 08/11/93 |
| 12. | Dr. Ghulam Rasul Chaudhry, Regional Director, Lahore. | -do- | -do- |
| 13. | Mr. Pervez S. Khawaja, ARD Hyderabad. | -do- | -do- |

- | | | | |
|-----|---|---|---|
| 14. | Mrs. Mussarrat
Anwar Sheikh
Programme Co-
ordinator | Norway study
Tour arranged
by NORAD | Norway,
Two
weeks
w.e.f.
15/11/93 |
| 15. | Malik Muhammad
Manzoor, Lecturer | -do- | -do- |
| 16. | Mrs. Shahida Naeem
Asstt. Professor | U.K. Training
under ODA
Phase-IV
Programme | U.K., Six
weeks
19/11/93 |
| 17. | Mr. Javed Mehmood
Kasuri, Deputy
Director, IET. | To attend the
commonwealth of
Learning
Regional Meeting | Sri Lanka,
Three days
w.e.f.
11/5/93 |
| 18. | Miss Tamkanat
Shaheen Niazi
Research Associate
BUESP | To attend a
training course
at IEC, London/
UKOU. | U . K . ,
Three
M o n t h
w.e.f.
07/05/93 |
| 19. | Mrs. Razia Abbas
Director, BUESP | To participate in
Round Table on
Gender Bias in
Distance Edu-
cation Material/
Resources. | Canada
Two days
w.e.f.
18/06/93 |
| 20. | Dr. M.S.K. Shibli
Professor in Urdu | To participate in
15th Commonwealth
Universities
Congress & Confe-
rence of Executive
Heads, University
of Wales. | U.K., one
week
w.e.f.
16/08/93 |

- | | | | |
|-----|-----------------------------------|---|---|
| 21. | Miss Munazzah
Khanum, Lecturer | UKOU training under
ODA Phase-IV pro-
gramme. | U.K., three
months
w.e.f.
11/08/93 |
| 22. | Mr. Ijaz Ahmed
Designer | Netherland Fellow-
ship programme,
1993/94. | Netherland
F o u r
months
w.e.f. |

04/09/93

Training/Participation of the AIOU
Employees with in the Country

<u>Sr. No.</u>	<u>Name and Designation</u>	<u>Subject and Duration</u>
1.	S. Mumtaz Hassan Assistant Registrar	Computer Orientation for Middle Managem- ent, One week, w.e.f. 23/01/93
2.	Mr. Muhammad Khurshid Controller of Exams.	Computer Orientation for Senior Managem- ent, One week, w.e.f. 06/02/93
3.	Mr. Shahid Jamil Asstt. System Programmer	Spread Sheet Analysis, One week, w.e.f. 20/02/93
4.	Mr. Majed Rashid Asstt. Professor	Course on "Enrolment Income & Resource mobilisation through decenterlization". Three weeks, w.e.f. 06/02/93
5.	Mr. Niaz Muhammad Stenotypist	Course on Word-Pro- cessing using Word Star. One week, w.e.f. 13/03/93.

- | | | |
|-----|--|--|
| 6. | Mr. M. Pervez Awan
Stenographer | Course on Word-
Processing, using
Word Star
One week, w.e.f.
06/03/93. |
| 7. | Mr. Farooq Qadir Khan
Stenographer | -do- |
| 8. | Mr. Zafar Ali
Stenographer | -do-
One week, w.e.f.
13/03/93. |
| 9. | Mr. M. Qasim Gujar
Stenotypist | -do-
One week, w.e.f.
02/05/93 |
| 10. | Mr. Muhammad Farooq
Stenotypist | -do- |
| 11. | Mr. Haq Nawaz
Stenotypist | Course on Word Proc-
essing using Word
Star. One week,
w.e.f. 12/06/93. |
| 12. | Mr. Hamad Aziz
S.G. UDC | -do |
| 13. | Mrs. Rifat Khalid
S.G. Assistant | -do- |
| 14. | Mrs. Hajira Ahmed
Lecturer | 'C' Language Pro-
gramming. Three
weeks, w.e.f.
10/04/93. |
| 15. | Dr. Nisar Ahmed Qureshi
Chairman, Deptt. of Urdu. | Seminar on New Edu-
cation Policy, 1992.
Two days, w.e.f.
09/04/93. |

- | | | |
|-----|---|---|
| 16. | Dr. M.A. Bukhari
Chairman, Deptt. of
Teacher Education. | National Policy &
Public awareness
conference on Drug
Abuse. 3 days w.e.f.
17/05/93. |
| 17. | Dr. S.A. Sherazi
Chairman, Deptt. of
Agri. Sc. | Computer Orientation
course for Senior
Management. One
Week, w.e.f.
17/04/93. |
| 18. | Mr. Liaqat Hussain
Incharge, Computer Centre. | Course on Computer
Facilities Manage-
ment One Week,
w.e.f. 22/05/93. |
| 19. | Mr. Hafeez Ullah
Registrar. | Course on Micro
Computer for Senior
Management. One
Week, w.e.f.
05/06/93. |
| 20. | Mrs. Bushra Shaheen
Lecturer. | Course on Electronic
Data Processing for
Management Ap-
plication (COBOL
Programing) Two
Months, w.e.f.
10/07/93. |

VC AIOU Gives away Prizes

The life has no charm without flowers. It is flower from which we not only prepare "Iter, medicines and dyer, but it has a far-reaching effects on the human psychology". These sentiments were expressed by Dr. M. Tariq Siddiqui, Vice-Chancellor, AIOU on the occasion of prize distribution ceremony , arranged for those gardeners of the university who had won the prizes in the exhibition held under the auspices of Islamabad Horticultural Society. The function for distribution of prizes was held in campus. The Vice-

Chancellor also announced special reward to be given to the winners of the exhibition by the university, as a sign of encouragement.

AIOU Monsoon Tree Plantation

The Allama Iqbal Open University fully utilize the days of Monsoon tree plantation campaign and planted about 1200 saplings of various kinds in the university presented by Mumtaz Khan, forest conservator, social forestry department, Swat.

AIOU Haj Draws

Since the last five years the AIOU sent every year, an employee in BPS-1 to 16 to perform Haj at the University expenses.

For the year 1993, Draws were held here on campus of AIOU in February, 1993 to nominate an official in BPS-1 to 16 and above 40 for performing Haj. Mr. Ghulam Hussain S/o Wali Muhammad, Naib Qasid was the recipient of the lucky draw.

PAKISTAN JOURNAL OF DISTANCE EDUCATION

Volume — X

1993

Issue — I & II



Allama Iqbal Open University
Islamabad — Pakistan

**DATA BANK
STATISTICAL GLIMPSES OF
ALLAMA IQBAL OPEN UNIVERSITY
ISLAMABAD**

BY

ABDUS SAT'TAR KHAN

**PROGRAMME/LEVEL-WISE AND GENDER-WISE COURSE ENROLMENT
WITH RESPECTIVE NUMBER OF COURSES DURING THE YEAR 1993**

Sr. No.	Programme/Level	No. of Courses	Semester Spring 1993			Semester Autumn 1993			Total 1993		
			M	F	T	M	F	T	M	F	T
1.	Functional (Non-Credit) Courses	2	228	115	343	252	112	364	480	227	707
2.	Women's Education (Matric)	19	-	2728	2728	-	2419	2419	-	5147	5147
3.	Intermediate	43	8253	6466	14719	7887	6285	14172	16140	12751	28891
4.	B.A/B.B.A/B.Com	62	11595	3654	15249	12054	3862	15916	23649	7516	31165
5.	MA (EPM)	7	70	33	103	277	88	365	347	121	468
6.	M.Sc Pakistan Studies	9	-	-	-	298	83	381	298	83	381
7.	M.B.A	29	4429	258	4687	2073	127	2200	6502	385	6887
8.	M.Ed (Diploma in Special Education)	1	-	-	-	41	22	63	41	22	63
9.	Teaching of English as Foreign Language (TEFL)	6	143	70	213	104	54	158	247	124	371
10.	Population Education (Post-graduate Level)	1	245	21	266	-	-	-	245	21	266
11.	B.Ed	14	24852	9304	34156	12165	4723	16888	37017	14027	51044
12.	CT	11	9654	4716	14370	5921	2647	8568	15575	7363	22938
13.	PTC	9	21776	14205	35981	15353	8656	24009	37129	22861	59990
14.	New PTOC	1	2555	1760	4315	-	-	-	2555	1760	4315
15.	ATTC	1	321	65	386	-	-	-	321	65	386
16.	M.Phil Iqbaliat	4	-	-	-	163	48	211	163	48	211
17.	M.Phil Islamiyat	4	-	-	-	190	32	222	190	32	222
18.	M.Phil Urdu	2	-	-	-	55	19	74	55	19	74
19.	M.Phil Education	6	-	-	-	65	32	97	65	32	97
Total		231	84121	43395	127516	56898	29209	86107	141019	72604	213623

**PROGRAMME/LEVEL-WISE AND SEMESTER-
WISE NUMBER OF BOOKS PRINTED DURING
THE YEAR 1993**

Sr. No.	Programme/Level	Semester Spring 1993	Semester Autumn 1993	Total
1.	Women's Education	1996	5996	7992
2.	Intermediate	58642	18520	77162
3.	B.A/B.B.A/B.Com	103717	22441	126158
4.	M.A (EPM)	690	3000	3690
5.	M.Sc (Pak.Studies)	1965	2900	4865
6.	Teaching of English as Foreign Language (TEFL)	4000	-	4000
7.	B.Ed	36458	5975	42433
8.	CT	33000	3000	36000
9.	PTC	66340	7321	73661
10.	New PTOC	15938	51023	66961
11.	M.Phil Iqbaliat	-	360	360
12.	M.Phil Islamiat	150	-	150
13.	M.Phil Urdu	-	967	967
14.	M.Phil Education	1190	1600	2790
Total		324086	123103	447189

**PROVINCE-WISE AND SEMESTER-WISE STATISTICS
OF TUTORS FOR AUTUMN 1992 AND SPRING 1993 SEMESTER**

	Semester Autumn 1992	Semester Spring 1993	Total
N.W.F.P	149	506	655
Baluchistan	24	28	52
Sindh	118	479	597
Punjab	679	1479	2158
Islamabad (F.A.)	98	175	273
Azad Jammu & Kashmir	43	67	110
Northern Areas	37	47	84
Total	1148	2781	3929

**PROVINCE-WISE AND SEMESTER-WISE
STATISTICS OF STUDY CENTRES FOR
AUTUMN 1992 AND SPRING 1993 SEMESTER**

Province	Semester Autumn 1992	Semester Spring 1993	Total
N.W.F.P.	39	71	110
Baluchistan	15	5	20
Sindh	38	108	146
Punjab	75	110	185
Federal Area (Islamabad)	4	5	9
Azad Jammu & Kashmir	3	3	6
Northern Area	4	5	9
Total	178	307	485

**RADIO/T.V PROGRAMMES PRESENTED IN
SPRING AND AUTUMN 1993 SEMESTER**

Programmes	Spring 1993	Autumn 1993	Total
Radio	229	193	424
T.V.	52	58	110

**RADIO/T.V PRODUCTION AND AUDIO/VIDEO
CASSETTES SALE DURING THE YEAR 1993**

Titles	Quantity
Total TV Programmes Production	24
Total Radio Broadcast Programmes	56
Total Radio Non-Broadcast Programmes	37
Total Sale Audio Cassettes	880
Total Sale Video Cassettes	147

STAFFING POSITION AS ON 31/12/93

	Academic Staff	Administrative & other Staff	Region	Total
17 and above	90	102	29	221
16 and below	-	631	193	824
Total	90	733	222	1045

Readers' Views

I have received copies of the Pakistan Journal of Distance Education and enjoy reading it very much.

Canada

Dr. John.R. Minis
University of Manitoba,

I received Vol. V-VIII, Issue-II of Pakistan Journal of Distance Education a few days ago. Thank you very much for your kind thinking of course, it looks nice. Also Dr. Barkan has received his copy. He requires to pass his regards to you.

Prof. Dr. Ugur Demicray

Please accept our congratulations for bringing out this excellent issue on distance education. We have added this publication to the collection of our library for preservation and use. I would be grateful if you kindly keep us in your mailing list for receiving this publication.

New Delhi

Dr. K.G. Tyagi
Indian Council of Social
Science Research,

I find the journal to be of a satisfactory standard which I hope will continue to be maintained.

Hyderabad (Sindh)

Dr. N.A. Baloch
University of Sindh,

According to the subject matters, your journal seems to be much informative and useful. On its publication, you as well as your Centre deserve congratulations.

Islamabad (Pakistan)

Dr. Jamil Jalibi
National Language
Authority

I find this journal quite relevant and congratulate the members of the Board for their contributions.

Islamabad

Dr. Shaukat Ali Siddiqi
Allama Iqbal Open University

This is of course a very useful and informative journal to keep in the library.

Islamabad

Sheikh M. Hanif
Quaid-i-Azam University



Printed by
Allama Iqbal Open University Printing Press,
Islamabad.